

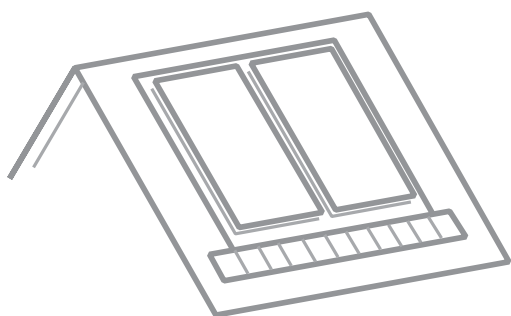

## Installation/Operating Manual



D  
GB  
F  
NL

---

D Montage- und Bedienungsanleitung, Art.-Nr.: 255 300, 02.2011, -01-  
GB Installation/Operating Manual, Art. No. 255 300, 02.2011, -01-  
F Manual de Montage et de conduite, Art.-Nr.: 255 300, 02.2011, -01-  
NL Montage-instructies en gebruiksaanwijzing, Art.-Nr.: 255 300, 02.2011, -01-

Printed in Germany

- 
- D Beachten Sie bitte vor der Montage die allgemeinen Informationen sowie die Sicherheits- und Gefahrenhinweise in dieser Anleitung.
- GB Before installation, please read carefully the general information and safety guidelines contained in these instructions.
- F Avant le montage, veuillez prendre note des informations générales, ainsi que des prescriptions de sécurité et des indications de dangers mentionnées dans le présent manuel.
- NL Gelieve de in deze handleiding vermelde algemene informatie en ook de veiligheidsinstructies en de aanwijzingen op gevaar vooraleer de montage door te voeren.

- D Zur bestimmungsgemäßen Verwendung gehört auch das Beachten der Montage- und Bedienungsanleitung.
- GB Correct usage also includes observing the assembly and operating instructions.
- F L'emploi conforme à la destination comporte également l'observation stricte des consignes de montage et de conduite.
- NL Tot een reglementair voorgeschreven toepassing behoort ook de inachtneming van de montage-instructies en van de gebruiksaanwijzing.

- D Bei unsachgemäßer Verwendung können Gefahren für Leib und Leben des Benutzers oder Dritter bzw. Beeinträchtigungen des Gerätes/der Anlage und anderer Sachwerte entstehen. Für hieraus resultierende Schäden haftet der Hersteller/Lieferant nicht. Das Risiko trägt allein der Anwender.
- GB Incorrect usage can result in serious injury or death to the user or a third party and harm the device or system and other material assets. The manufacturer/supplier shall not be liable for any damage arising.
- F Une utilisation non conforme à la destination peut générer des dangers corporels et mortels pour l'utilisateur ou une tierce personne les appareils, l'installation ou d'autres valeurs matérielles pourraient être endommagés. Le fabricant et le fournisseur déclinent la responsabilité pour les dommages qui en résultent. Le risque incombe exclusivement à l'utilisateur.
- NL Bij onvoldoende voordruk stikstof voor een drukverhoging door middel van het voordrukventiel toevoeren, bij een te hoge voordruk stikstof aan het voordrukventiel laten wegvloeien. Voor daaruit voortvloeiende beschadigingen kan de fabrikant/leverancier niet aansprakelijk gesteld worden. Het risico draagt enkel en alleen de gebruiker.

- D Bitte beachten Sie folgende Hinweise auf Gesetze, Verordnungen und Technische Regeln
- Bei der Erstellung solartechnischer Anlagen sind die für das jeweilige Land geltenden Gesetze und Verordnungen auf Landes-, Bundes- und europäischer, bzw. internationaler Ebene zu beachten.
- Es gelten generell die allgemein anerkannten Regeln der Technik, die üblicherweise in Form von Normen, Richtlinien, Vorschriften, Bestimmungen und technischen Regeln von Landes- und Bundesorganisationen, Energieversorgungsunternehmen, sowie Fachverbänden und -ausschüssen für den betreffenden Fachbereich formuliert wurden. Die Montage von Solarelementen stellt unter Umständen eine erhöhte Anforderung an die Regensicherheit im Rahmen der Dach-, Wand- und Abdichtungstechnik dar und ist entsprechend zu berücksichtigen.
- Zur Einhaltung der Vorschriften zur Unfallverhütung kann die Verwendung von Sicherungssystemen (Gurte, Einrüstungen, Fangeinrichtungen etc.) erforderlich sein.
- Diese Sicherungssysteme gehören nicht zum Lieferumfang und sind gesondert zu bestellen. Die Montage darf nur durch fachlich qualifiziertes und autorisiertes Personal mit einem anerkannten Ausbildungsnachweis (durch eine Landes- oder Bundesorganisation) für den jeweiligen Fachbereich erfolgen.
- F Veuillez tenir compte des indications suivantes relatives aux lois, décrets et règlements techniques.
- Lors de la réalisation d'installations solaires, il convient de respecter la législation et la réglementation en vigueur aux niveaux régional, national, européen ou international s'appliquant au pays concerné.
- Les règles techniques généralement admises s'appliquent. Celles-ci sont habituellement formulées par les organismes régionaux et nationaux, les distributeurs d'énergie, ainsi que les associations professionnelles et les comités d'experts des domaines techniques concernés sous forme de normes, directives, prescriptions, dispositions et règlements techniques.
- Le montage d'éléments solaires est, le cas échéant, très exigeant quant à la résistance de la sous-construction existante et l'étanchéité à la pluie dans le cadre de la technique d'étanchement du toit et des murs: il faut donc en tenir compte. L'emploi de dispositifs de sécurité (ceintures, équipements, dispositifs d'arrêt, etc.) peut s'avérer nécessaire, afin de répondre aux exigences en matière de prévention des accidents. Ces dispositifs de sécurité ne sont pas inclus dans la livraison et doivent être commandés séparément.
- Seul un personnel dûment qualifié et autorisé, disposant d'un certificat de formation (délivré par une institution régionale ou nationale) du domaine technique concerné, peut procéder au montage.
- GB Please note the following instructions regarding laws, regulations and technical rules.
- When setting up solar energy installations, the laws and regulations at local, state, European and international level that apply to the country in question must be observed. Generally acknowledged technical regulations apply; these are usually formulated in the form of standards, guidelines, provisions, regulations and technical rules laid down by local and national bodies, energy supply companies, trade organisations and technical committees in the relevant fields. The installation of solar units may require improved rain resistance with regard to roof, wall and sealing technology and must be taken into account accordingly. To meet regulations for the prevention of accidents, it may be necessary to use safety equipment (straps, scaffolding, supports, etc.). Such safety equipment is not supplied and must be ordered separately. Installation must only be carried out by technically qualified and authorised personnel with a recognised qualification (verified by a state or national body) in the relevant technical area.
- NL Gelieve de hierna volgende opmerkingen over de wetten, verordeningen en technische regels in acht te nemen
- Bij de aanmaak van zonnetechnische installaties dienen de voor het respectievelijke land geldende wetten en verordeningen op regionaal, nationaal en internationaal niveau in acht genomen te worden.
- Over het algemeen zijn de algemeen erkende regels van de techniek van toepassing, die gewoonlijk in de vorm van normen, richtlijnen, voorschriften, bepalingen en technische regels vanwege de regionale en nationale organisaties, energiebedrijven en ook vakverenigingen en -comités voor het desbetreffende vakgebied geformuleerd werden.
- De montage van zonne-elementen vormt soms verhoogde eisen aan het dragende vermogen van de bestaande onderconstructie en aan de regenveiligheid in het kader van de dak-, wand- en afdichtingstechniek en er dient op gepaste wijze rekening mee gehouden te worden.
- Voor de inachtneming van de voorschriften ter preventie van ongevallen kan het gebruik van beveiligingssystemen (gordels, steigers, vanginrichtingen etc.) noodzakelijk zijn.
- De montage mag uitsluitend door deskundig, gekwalificeerd en gemachtigd personeel met een erkend scholingsbewijs (door een regionale of een nationale organisatie) voor het respectievelijke vakgebied gebeuren.

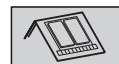

3-5	D Allgemeine und rechtliche Hinweise GB General information and legal references F Indications générales et juridiques NL Algemene en juridische aanwijzingen	15	D Übersicht: Montagesystem, horizontal GB Overview: Installation system, horizontal F Aperçu: Système de montage, horizontal NL Overzicht: montagesysteem, horizontaal
6	D Erläuterung der verwendeten Piktogramme GB Explanation of pictograms used F Explication des pictogrammes utilisés NL Toelichting van de gebruikte pictogrammen	18	D Abmessungen, horizontal GB Dimensions, horizontal F Dimensions, horizontales NL Afmetingen, horizontaal
7	D Produktbeschreibung GB Product description F Description de produit: NL Productbeschrijving	19	D Abmessungen, vertikal GB Dimensions, vertical F Dimensions, verticales NL Afmetingen, verticaal
8	D Warnhinweise GB Warnings F Avertissements NL Waarschuwendende aanwijzingen	20-27	D Montage: Basis 2er Senkrecht GB Installation: 2 Collector Portrait In-Roof Basic Kit F Montage: Kit de base de 2 capteurs verticaux NL Montage: basis 2 collectoren verticaal
9-10	D Lieferumfang / Bedarfsermittlung GB Scope of supply / Ascertainment of need F Etendue de la livraison / Détermination des besoins NL Omvang van de levering / Vaststelling van benodigdheden	28-29	D Kollektormontage GB Collector installation F Montage de capteurs NL Collectormontage
11	D zusätzlich erforderlich GB Also required F Nécessaire en supplément NL Aanvullend noodzakelijk	30-31	D Hydraulischer-Anschluss GB Hydraulic installation F Raccordement hydraulique NL Allacciamento idraulico
12	D Übersicht: Montagesystem, vertical GB Overview: Installation system, vertical F Aperçu: Système de montage, vertical NL Overzicht: montagesysteem, verticaal	32	D Dachdurchführungen GB Roof penetration F Traversée de toiture NL Dakdoorvoering
13	D Übersicht: Montagesystem, horizontal GB Overview: Installation system, horizontal F Aperçu: Système de montage, horizontal NL Overzicht: montagesysteem, horizontaal	33-34	D Montage: Oberes Eindeckblech, Formteilanschluss GB Montage: Top cover plate F Montage: Tôle de recouvrement supérieur, raccordement par pièce moulée NL Montage: bovenste afdekplaat, vormstukaansluiting
14	D Übersicht: Montagesystem, vertikal GB Overview: Installation system, vertical F Aperçu: Système de montage, vertical NL Overzicht: montagesysteem, verticaal	35	D Technische Daten GB Technical data F Spécifications techniques NL Technische gegevens



D Achtung, Gefahr für Umwelt und Produkt  
 GB Warning, danger to environment and products  
 F Gare aux dangers pour l'environnement et le produit !  
 NL Opgelet! Gevaar voor milieu en product!



D Wichtiger Hinweis:  
 GB Important note:  
 F Remarque importante:  
 NL Belangrijke opmerking:



D Hinweis, Information  
 GB Advice, information  
 F Remarque, Consignes  
 NL Opmerking, aanwijzingen



D Handfest  
 GB Hand tight  
 F Réglage manuel  
 NL Losvast



D Fest anziehen  
 GB Tighten firmly  
 F Resserrer fermement  
 NL Vast aantrekken



D Siehe Seite  
 GB See page  
 F Consulter la page  
 NL Zie pagina



D Maße  
 GB Dimension  
 F Mesure  
 NL Maat



D Bauseits zu stellende Materialien  
 GB Materials to be provided  
 F Matériels à fournir pour la mise en œuvre  
 NL Door klant te leveren materiaal



D Dachdurchführung  
 GB Roof penetration  
 F Traversée de toiture  
 NL Dakdoorvoering



D Orthogonal  
 GB Orthogonal  
 F Orthogonal  
 NL Orthogonaal



D Montage weiterer Kollektoren  
 GB Installation of additional collectors  
 F Montage d'autres capteurs  
 NL Montage van andere collectoren



D autorisierte Fachkraft erforderlich  
 GB authorized personnel required  
 F Faire appel à un expert autorisé  
 NL Gemachtigde vakman vereist



D Achtung! Verbrühungsgefahr  
 GB Warning! Danger of scalding  
 F Attention! Danger de brûlures!  
 NL Opgelet! Gevaar voor brandwonden



D Verletzungsgefahr  
 GB Danger of injury  
 F Risque de blessures  
 NL Gevaar voor verwondingen



D Grundset  
 GB Basic kit  
 D Jeu de pièces de base  
 NL Basisset



D Erweiterungsset  
 GB Enhancement kit  
 F Jeu de pièces d'extension  
 NL Uitbreidingsset



D Zubehörset  
 GB Accessory kit (vertical)  
 F Jeu d'accessoires  
 NL Toebehorensset

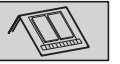

- D** Die Montage-Sets sind als Befestigungssysteme für Solarelemente konstruiert und dürfen nur ihrem statischen Nachweis entsprechend verwendet werden.  
Sie sind für Dächer mit Dachneigungen von 22° bis 65° ausgelegt. Die Montage auf flachen geneigten Dächern erfordert ein spezielles Montage-Set.  
Die bestimmungswidrige Verwendung, sowie unzulässige Änderungen bei der Montage und an der Konstruktion führen zum Ausschluss jeglicher Haftungsansprüche.
- GB** Installation kits have been designed as a fixing system for solar units and must only be used in accordance with their stated structural capability. They are designed for roofs with inclines from 22° to 65°. Installation on roofs with shallow pitch requires a special installation kit.  
Inappropriate use of the design and changes that are not permitted for the installation will invalidate all liability claims.
- F** Les jeux de pièces de montage conçus comme systèmes de fixation pour des éléments solaires ne doivent être employés que conformément à leur destination.  
Ils sont dimensionnés pour les toits ayant une pente de 22° à 65°. Le montage sur les toits à faible pente exige un jeu spécial de pièces de montage.  
L'utilisation contraire à la destination ainsi que les modifications du montage et de la construction auront pour conséquence l'exclusion de la responsabilité.
- NL** De montagesets zijn als bevestigingsystemen voor zonne-elementen geconstrueerd en mogen uitsluitend in overeenstemming met hun statische bewijs gebruikt worden.  
Ze zijn voor daken met dakhellingen van 22° tot 65° bestemd. De montage op vlak hellende daken vereist een speciale montageset.  
Een in strijd met de bepalingen zijnde toepassing evenals ongeoorloofde wijzigingen bij de montage en aan de constructie leiden tot uitsluiting van iedere aansprakelijkheidsclaim.

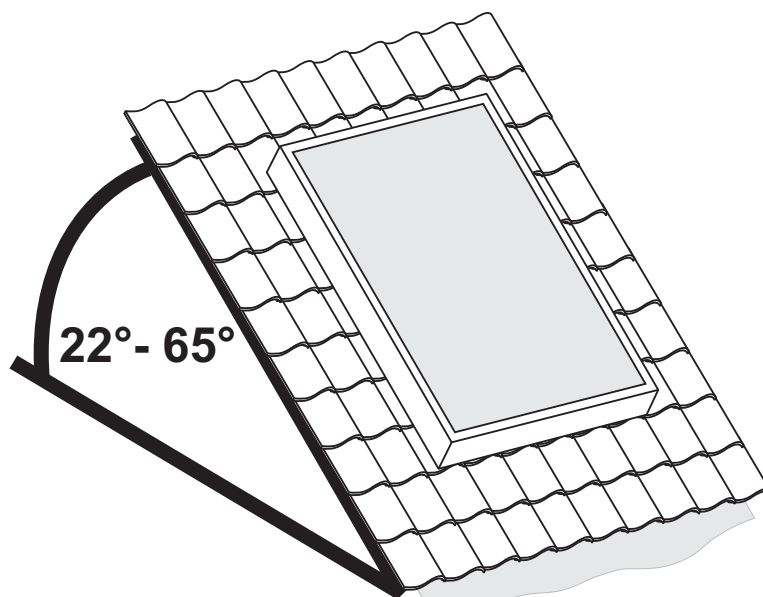
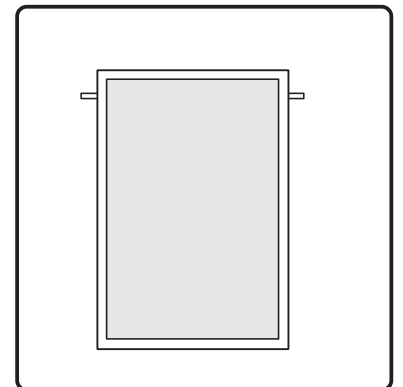

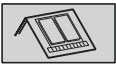

>70 °C

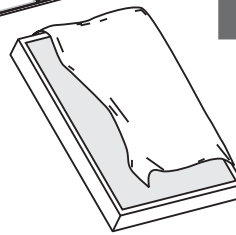
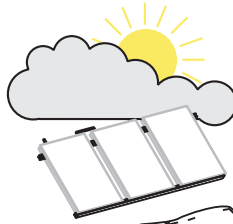
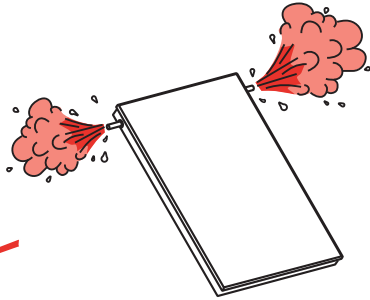
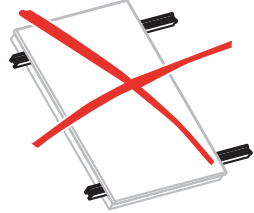

≤ 70 °C

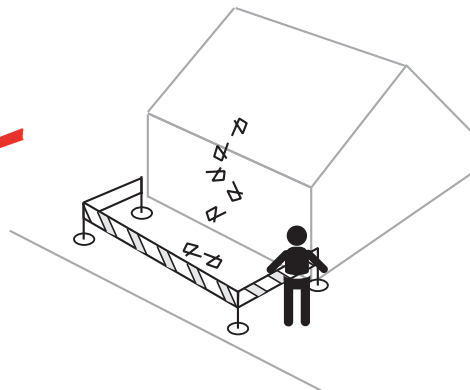
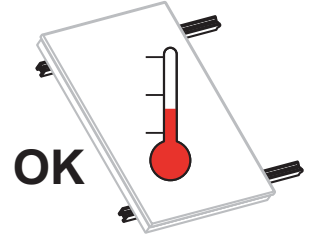

**i**

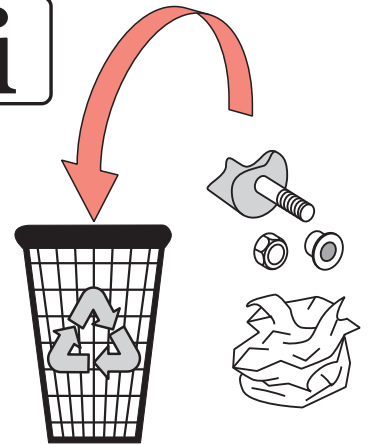





**i**

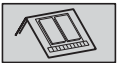

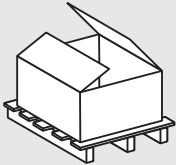
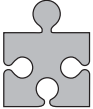
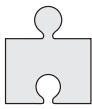
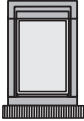
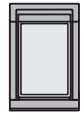

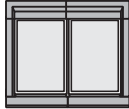

			
D 1er senkrecht, Ziegel GB 1 collector portrait in-roof kit, tile F 1 capteur vertical, tuile NL 1 collector verticaal, baksteen	1	-	
D 1er senkrecht, Schiefer GB 1 collector portrait in-roof kit, slate F 1 capteur vertical, ardoise NL 1 collector verticaal, leisteen	1	-	
D Basis 2er senkrecht, Ziegel GB 2 collector portrait in-roof kit, tile F Kit de base de 2 capteurs verticaux, tuile NL Basis 2 collectoren verticaal, baksteen	1	-	
D Basis 2er senkrecht Schiefer GB 2 collector portrait in-roof kit, slate F Kit de base de 2 capteurs verticaux, ardoise NL Basis 2 collectoren verticaal leisteen	1	-	
D Erweiterung senkrecht Ziegel GB 1 collector portrait in-roof ext. kit, tile F Kit d'extension capteur vertical, tuile NL Uitbreiding verticaal baksteen	-	1	
D Erweiterung senkrecht Schiefer GB 1 collector portrait in-roof ext. kit, slate F Kit d'extension capteur vertical, ardoise NL Uitbreiding verticaal leisteen	-	1	

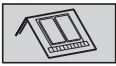

D Montagebretter  
 GB Mounting battens  
 F Planches de montage  
 NL Montageplanken

		30 x 50 [mm]			
		30 x 90 [mm]	1 x 1550 mm 2 x 1550 mm	1 x 2800 mm 2 x 2800 mm	1 x 4050 mm 2 x 4050 mm

D Zusätzlich Montagebretter der Verpackung entnehmen!  
 GB Extra Mounting battens are part of packaging!  
 F Sortir les planches de montage supplémentaires de l'emballage!  
 NL Bijkomend montageplanken uit de verpakking verwijderen!

			 30 x 90 x 2400 [mm]
	1 VE		2 x 2400 mm
	1 VE		2 x 2400 mm
	1 VE	1 VE	4 x 2400 mm

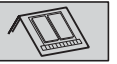

D Lüftungspfanne, individuelle Dacheindeckung beachten.  
 GB Ventilation roofing tile, individual roofing consider.  
 F Tuiles d'aération, Considérer la toiture individuelle.  
 NL Verluchtingsdakpan, Dakafdekking in acht nemen.

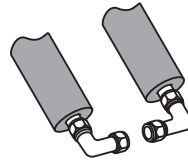

D Kollektorfeld-Anschlussset, gebogen  
 GB Collector connection kit, bent  
 F Kit de connexion pour capteur, courbé  
 D Collectorveld-aansluitset, gebogen



D Absturzsicherung  
 GB Antifall guard  
 F Protection anti-chute  
 NL Valbeveiliging

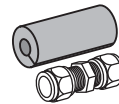

D Kollektorverbinder, gerade  
 GB Collector connector, straight  
 F Attache de capteur, droit  
 D Collectorverbindingsstuk, recht



D Temperaturfühler  
 GB Temperature sensor  
 F Sonde de température  
 NL Temperatuurvoeler

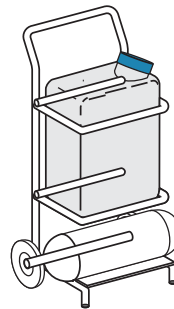

D Befüllstation  
 GB Filling station  
 F Station de remplissage  
 NL Vulstation



D Wärmeleitpaste  
 GB Thermal conducting paste  
 F Pâte thermoconductrice  
 NL Warmtegeleidende pasta



D Solarflüssigkeit  
 GB Solar fluid  
 F Liquide solaire  
 NL Zonnevloeistof

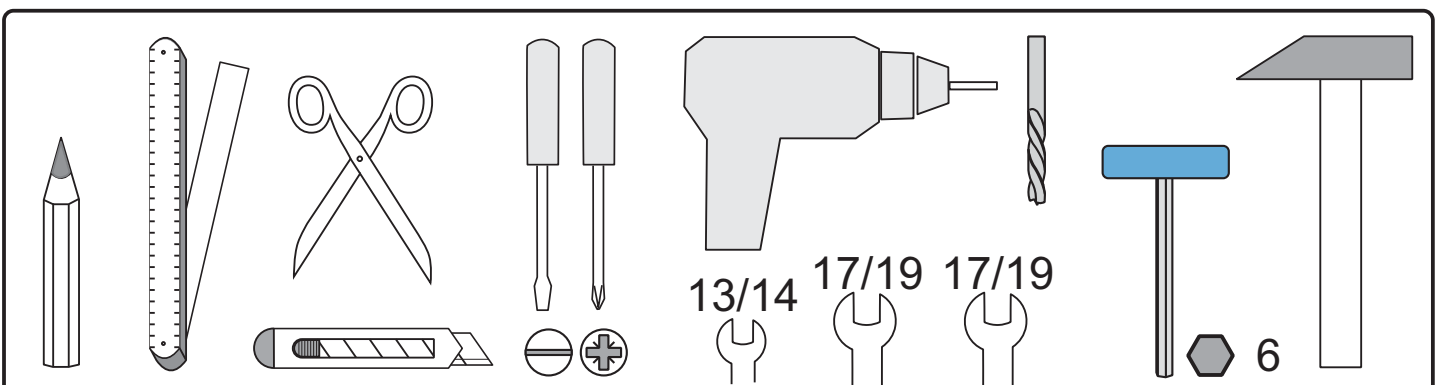

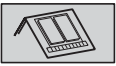

- D Das in dieser Montage- und Bedienungsanleitung verwendete Solarelement dient nur als Beispiel. Gegebenenfalls müssen die hier angegebenen Maße und Daten individuell angepasst werden!
- GB The solar unit used in these assembly and operating instructions is only given as an example. The dimensions and data given here must be tailored, if necessary, to individual requirements.
- F L'élément solaire utilisé dans les instructions de montage et de service ne sert que d'exemple. Les dimensions et données qui y sont indiquées le cas échéant doivent être adaptées individuellement!
- NL Het in deze montage-instructies en gebruiksaanwijzing gebruikte zonne-element dient slechts als voorbeeld. Eventueel moeten de hier aangegeven maten en gegevens individueel aangepast worden!

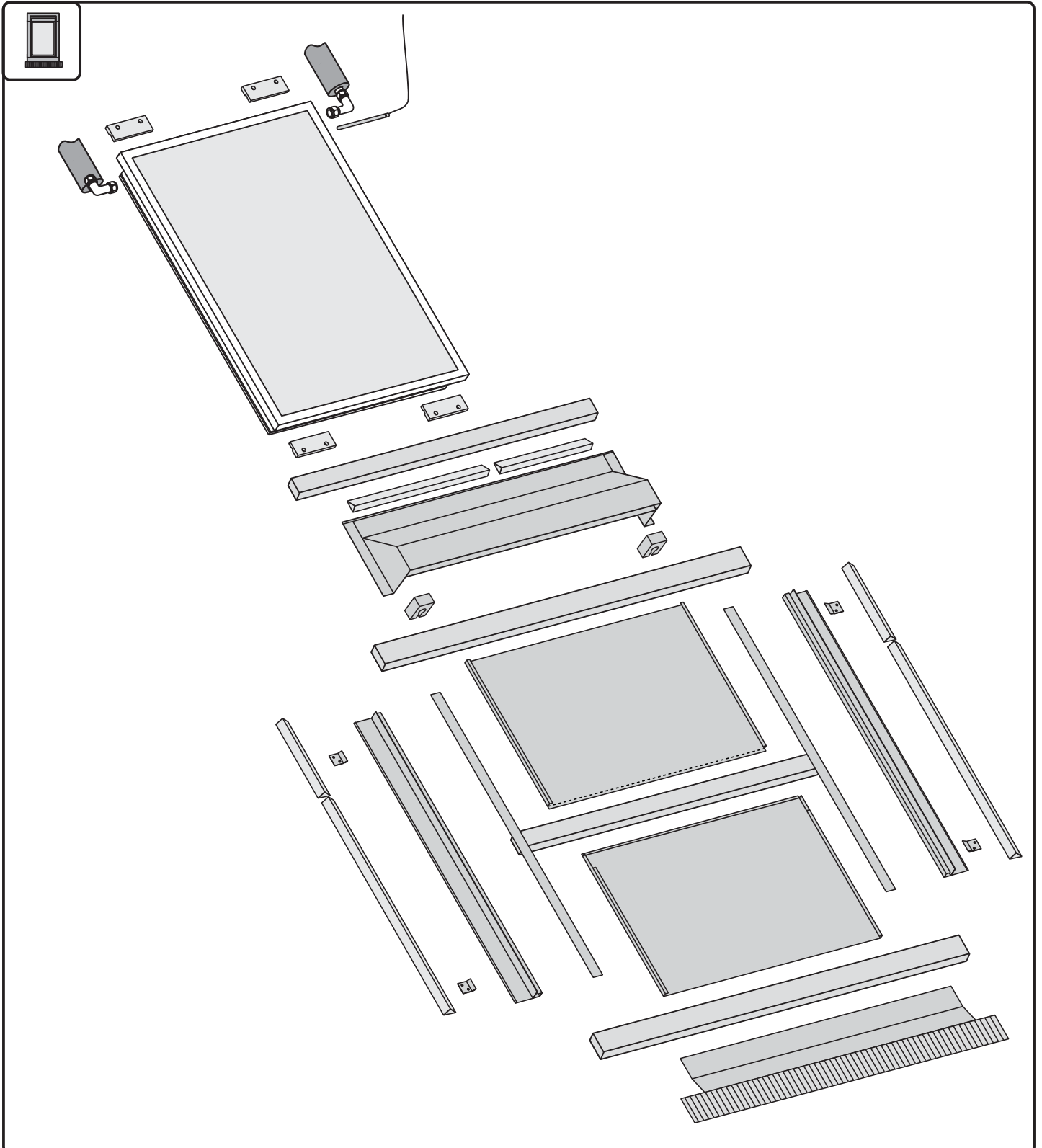

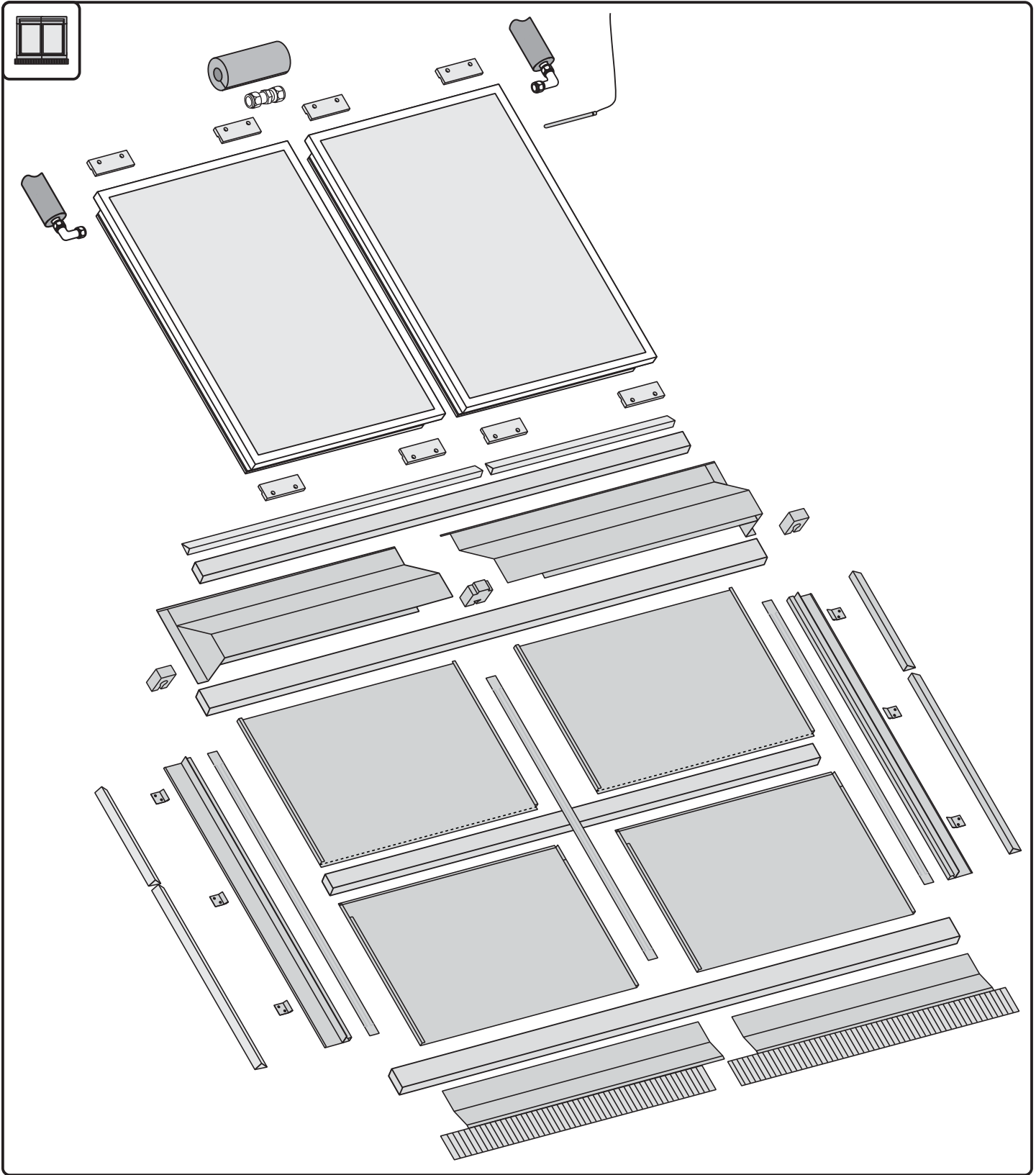

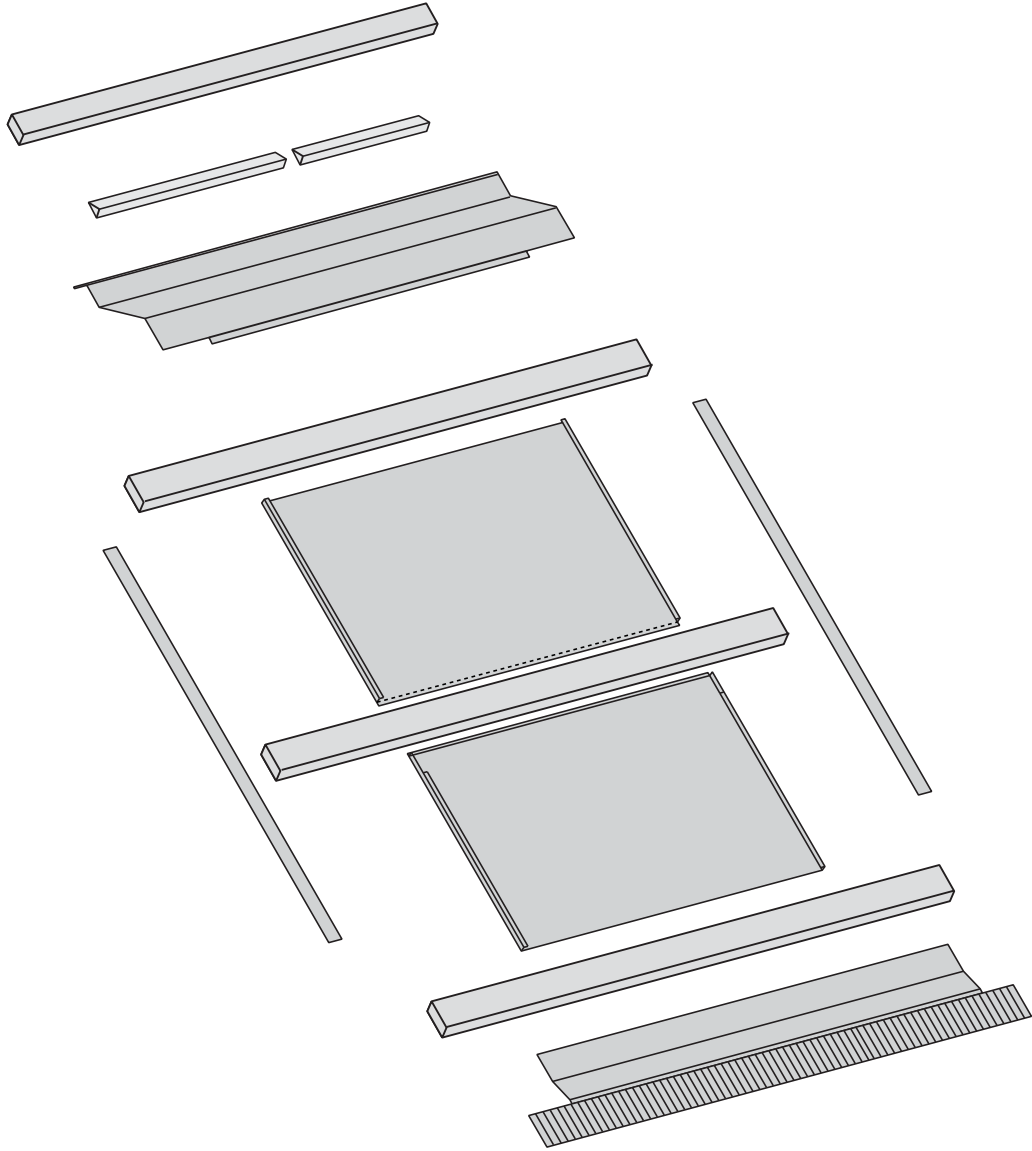
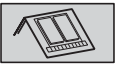

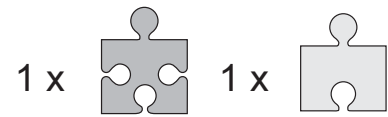
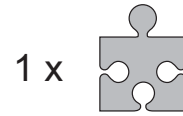
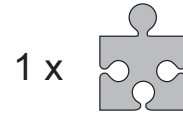
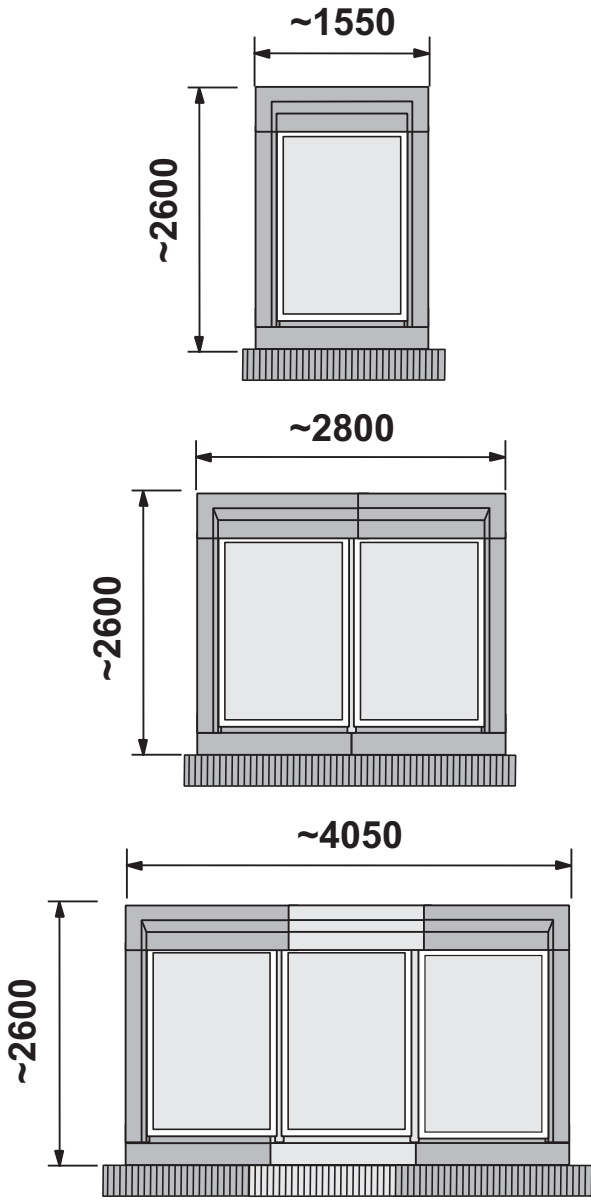
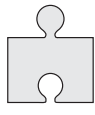
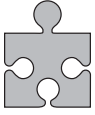
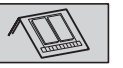

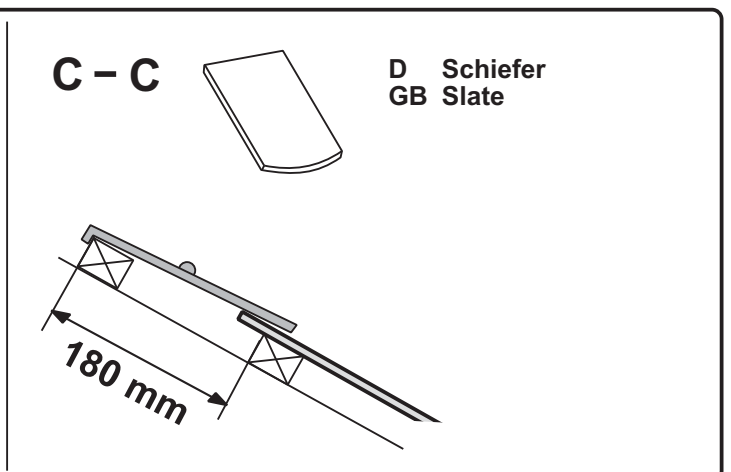
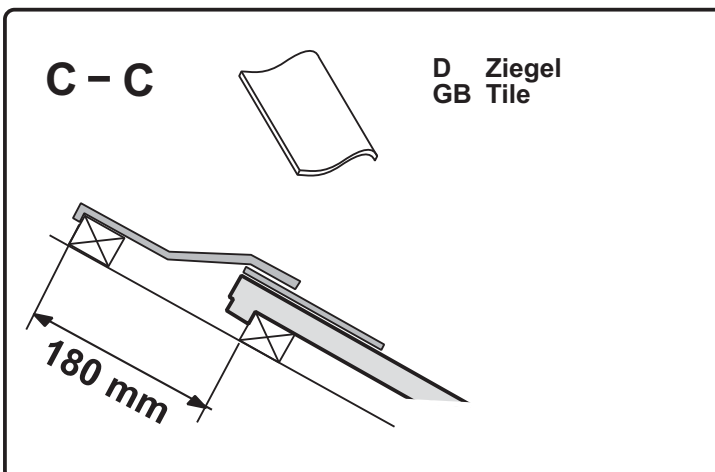
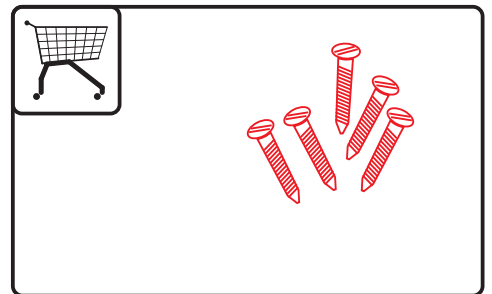
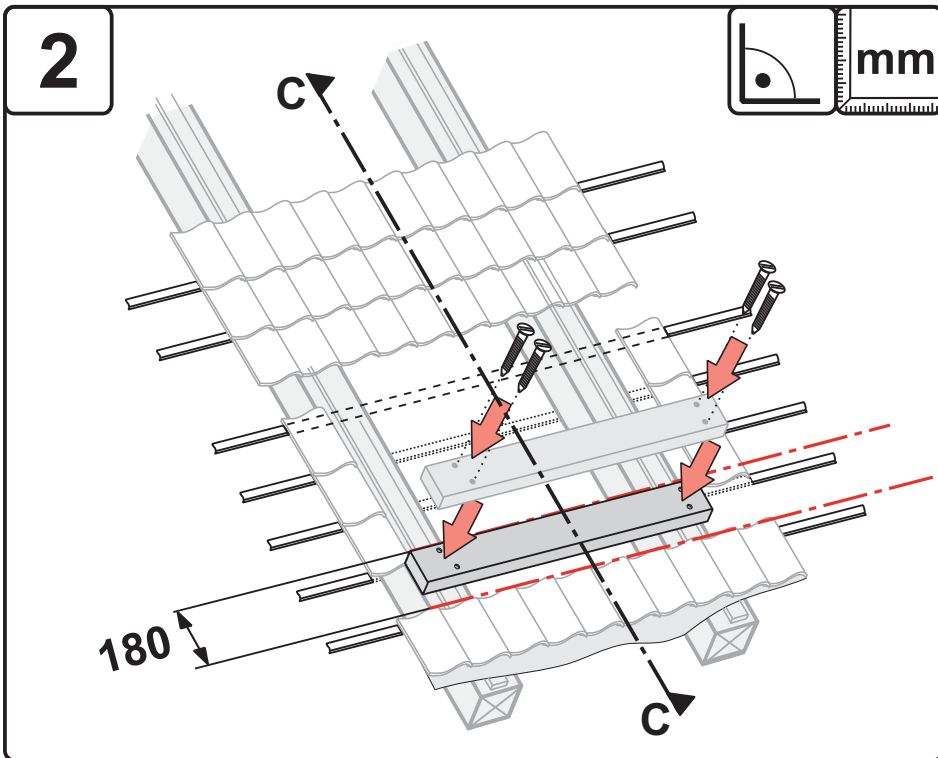
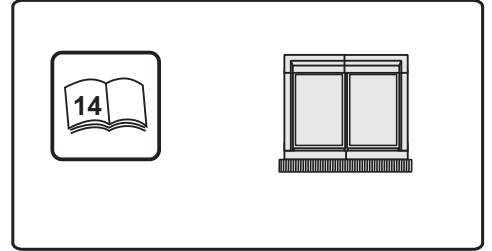
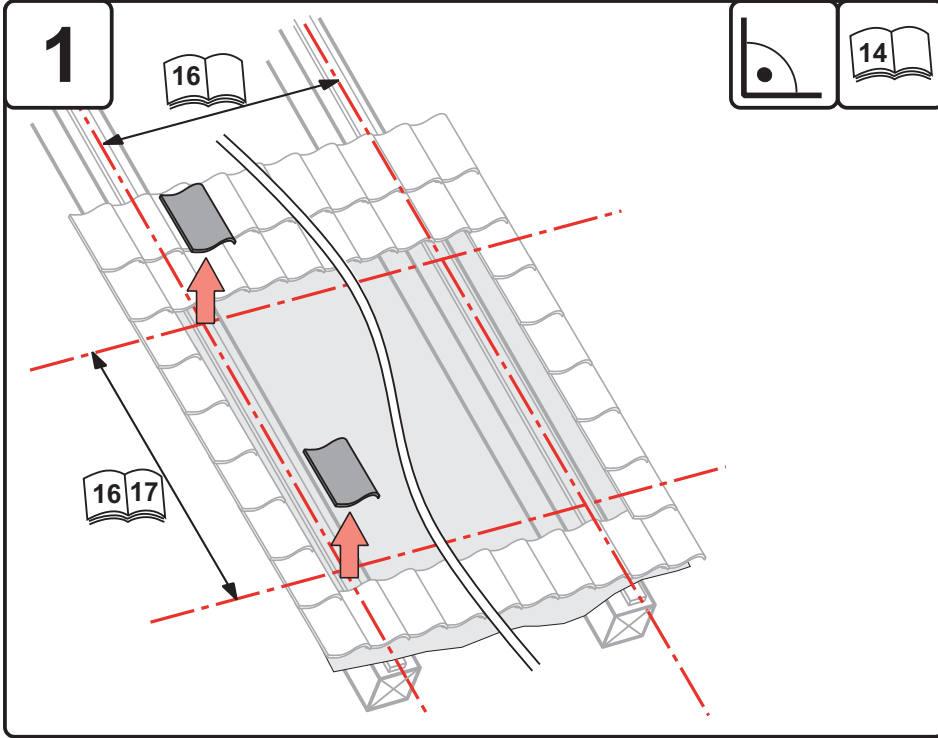
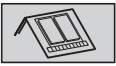



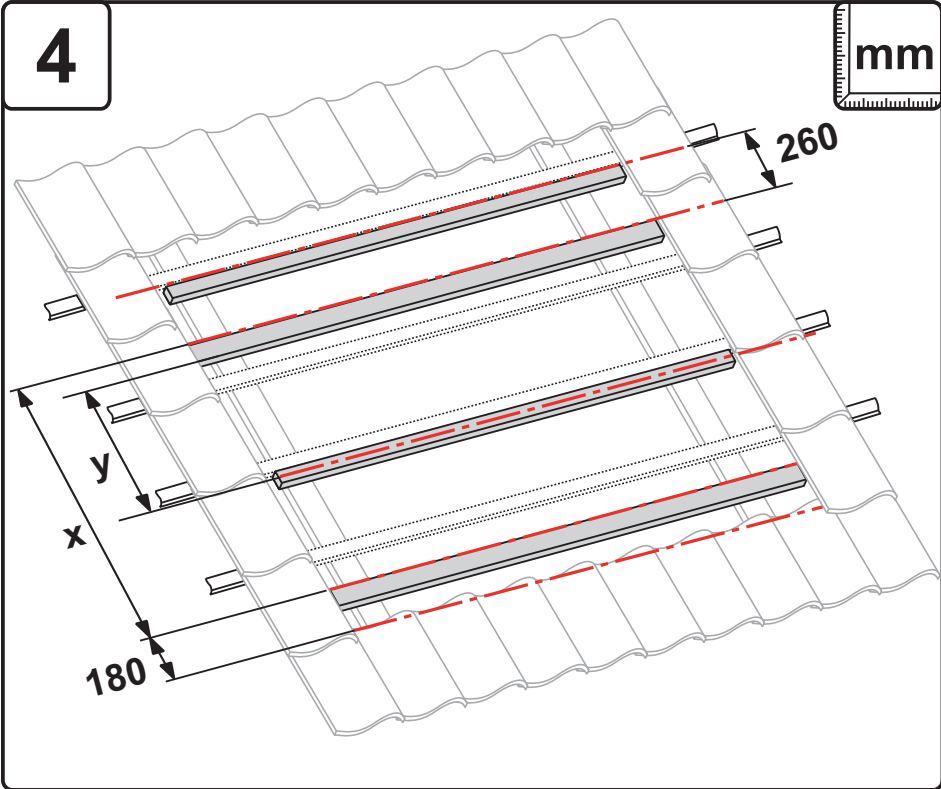
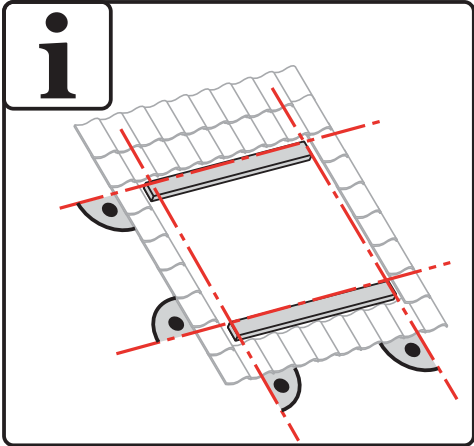
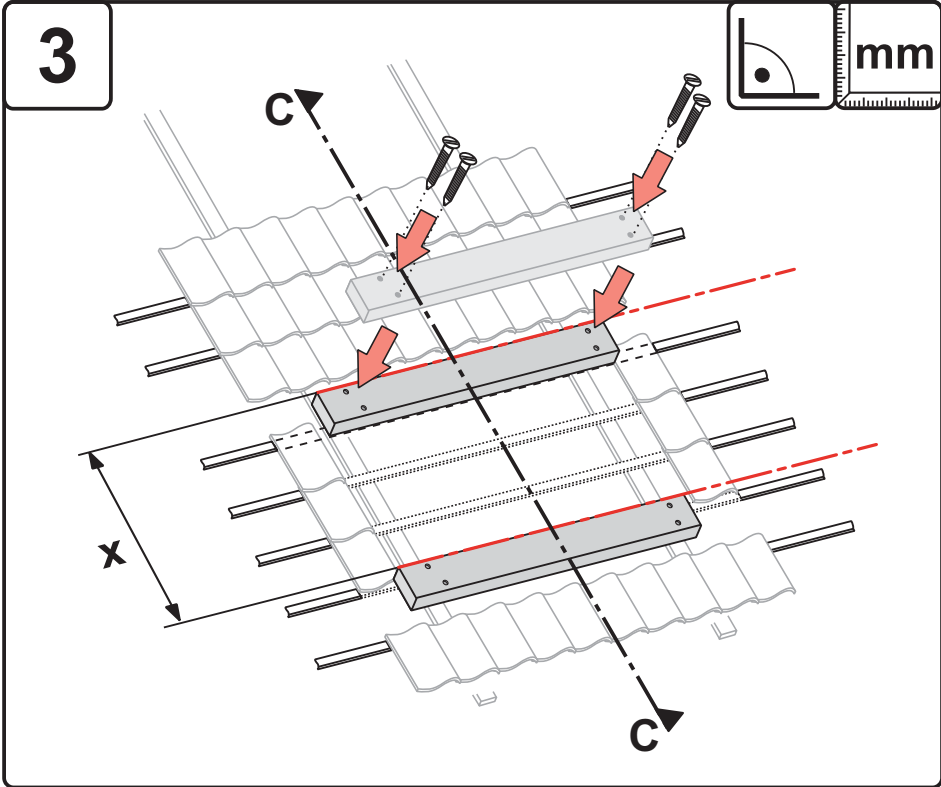
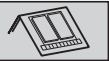

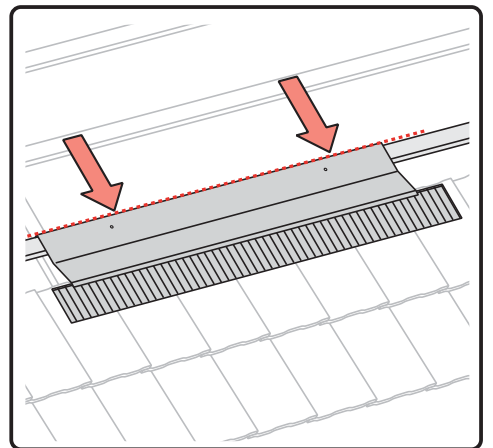
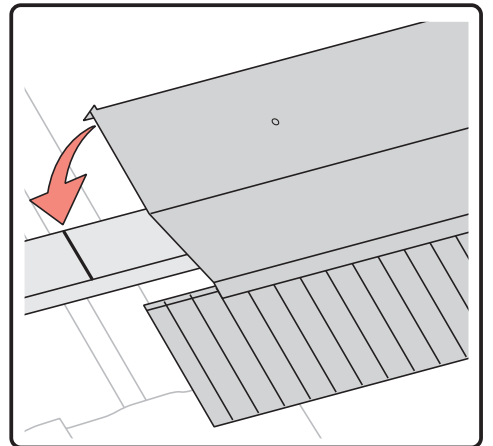
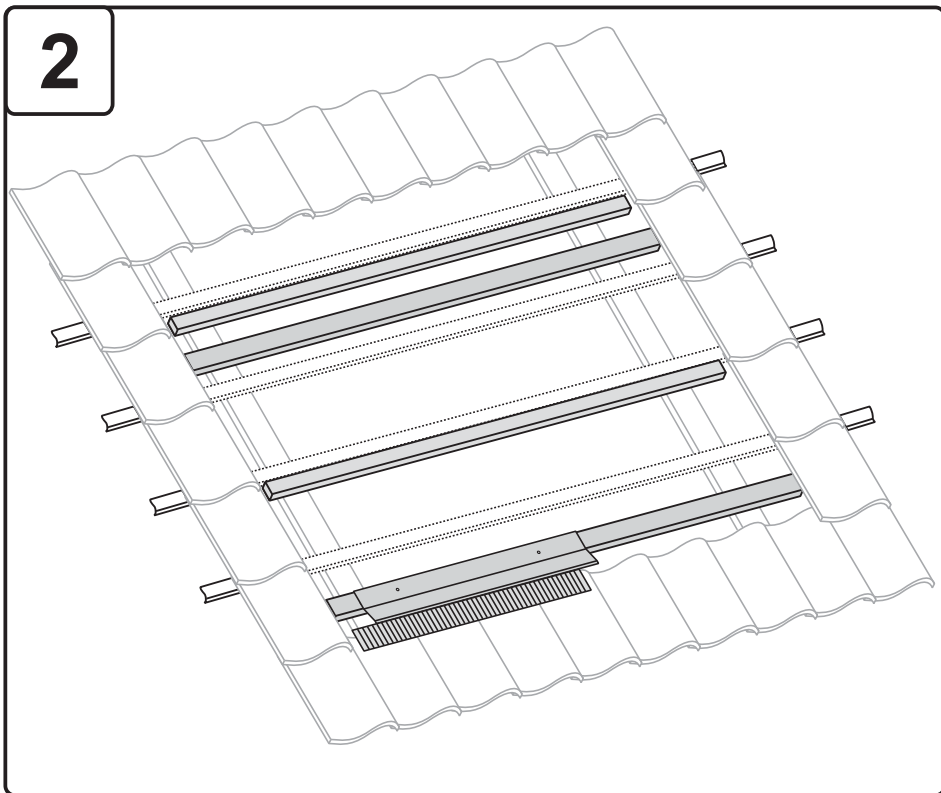
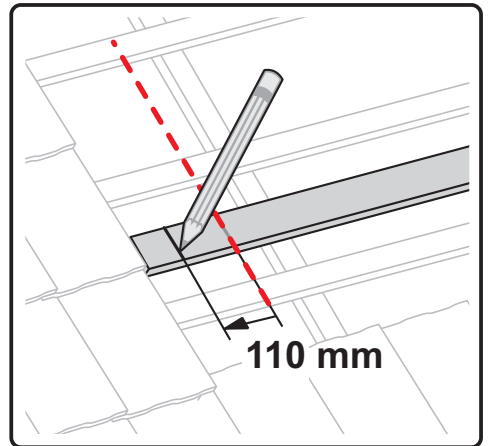
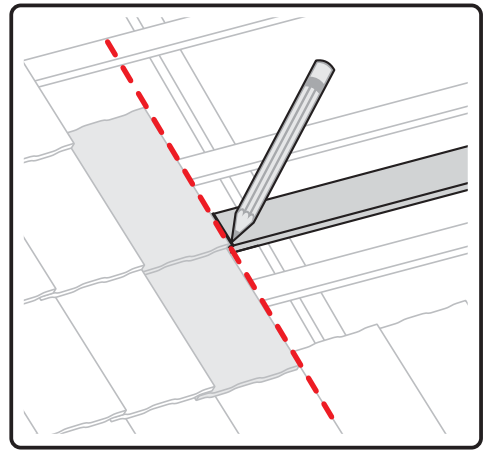
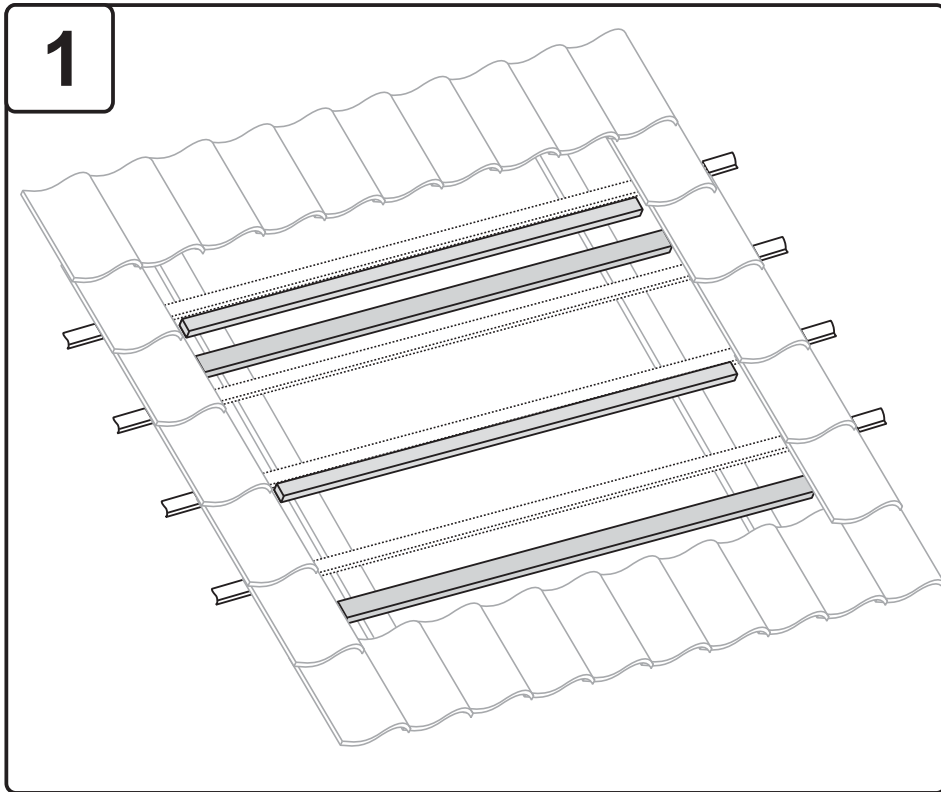
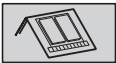

x [mm]	2160
y [mm]	1040

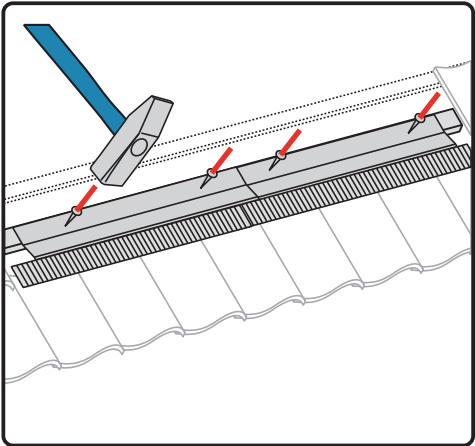
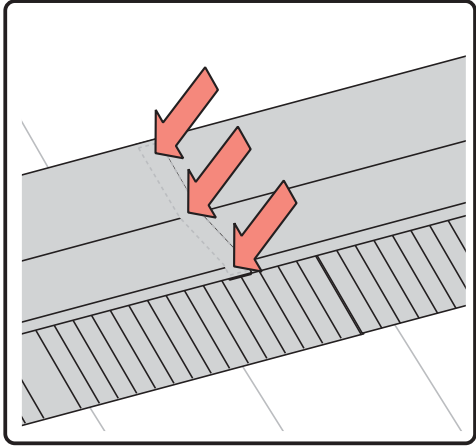
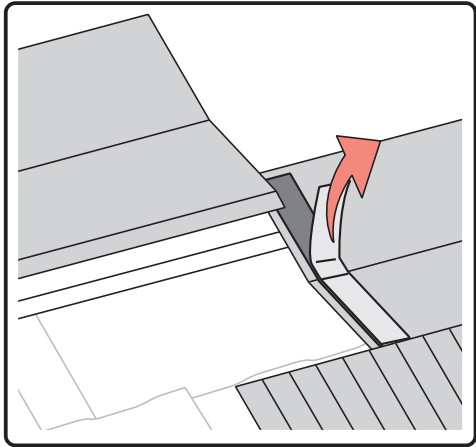
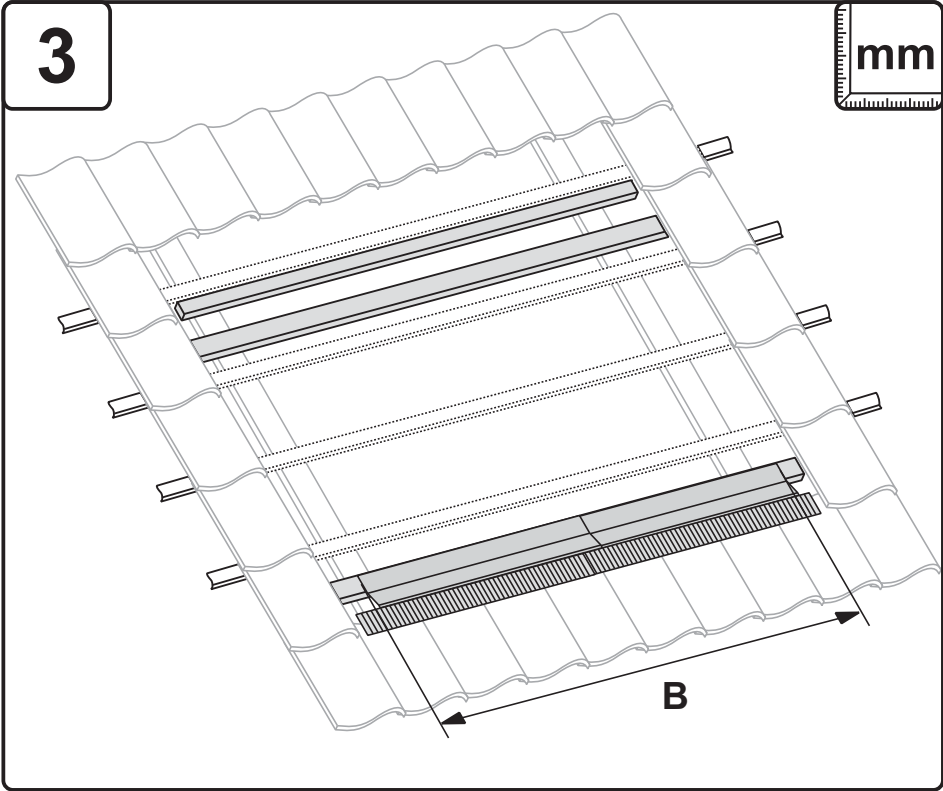

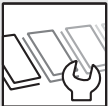

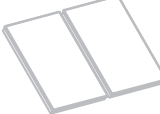
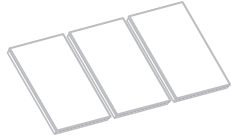
 <b>B</b> [mm]			
	<b>1550</b>	<b>2800</b>	<b>4050</b>

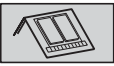

4

mm

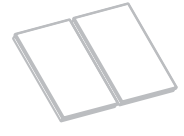
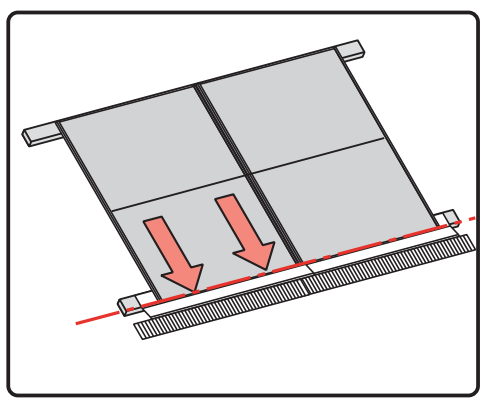
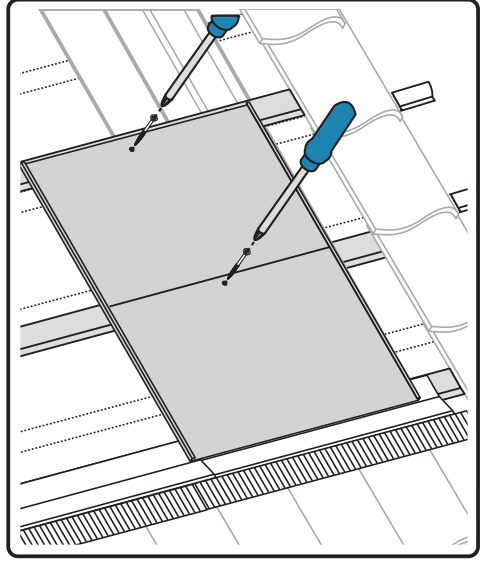
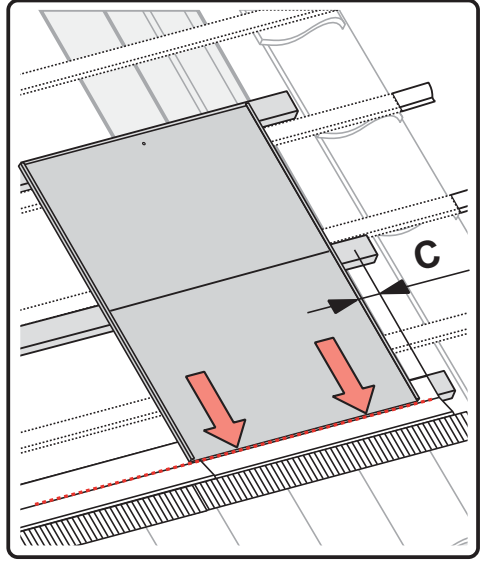
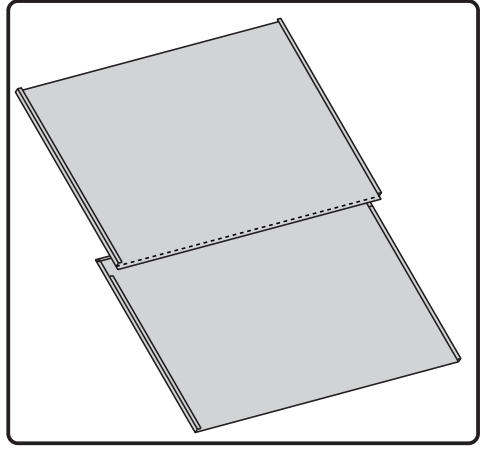
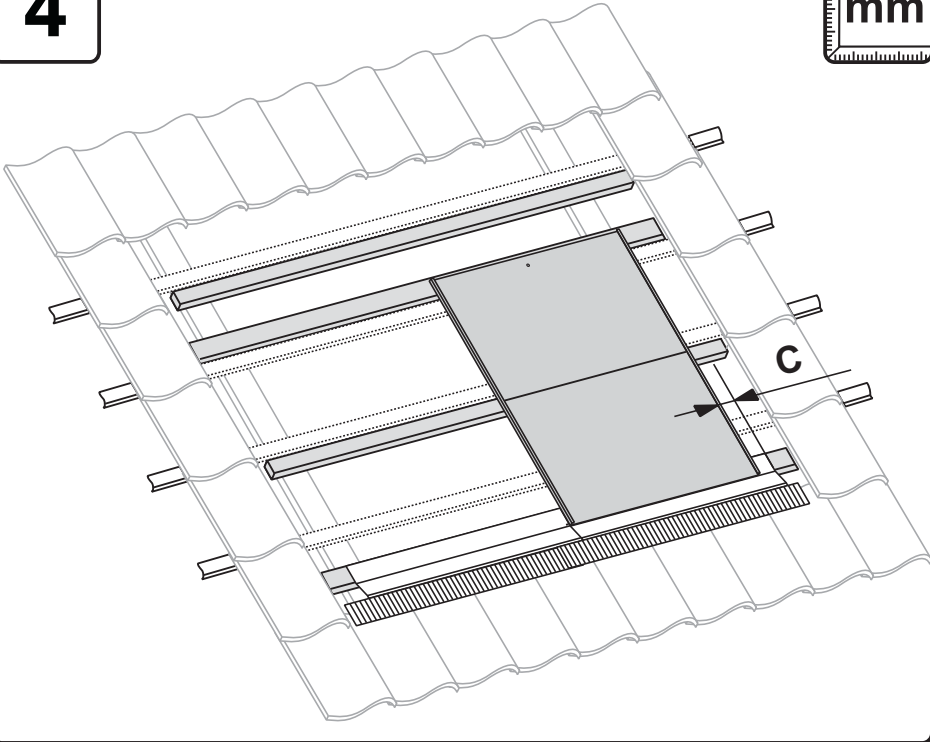

C [mm] 145



D Schiefer  
GB Slate

mm

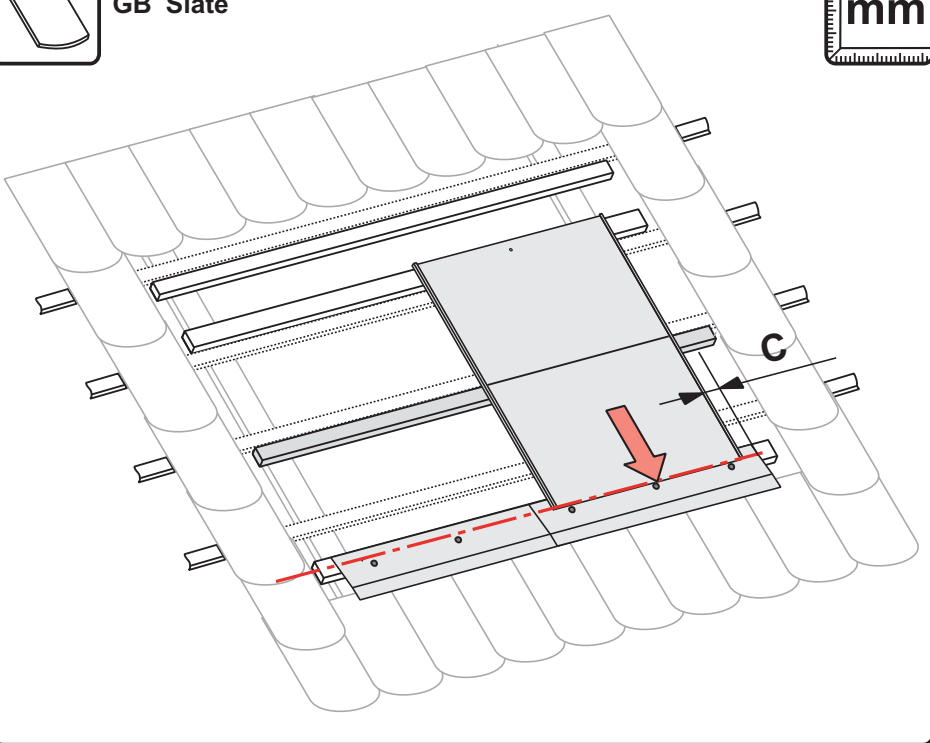



5

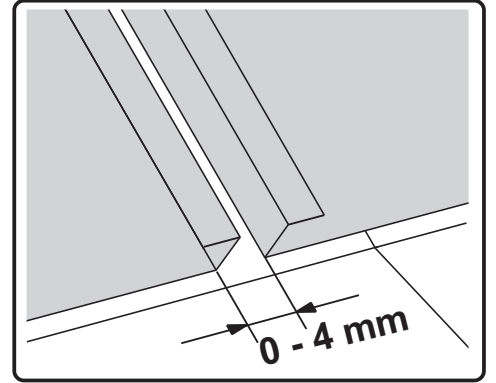
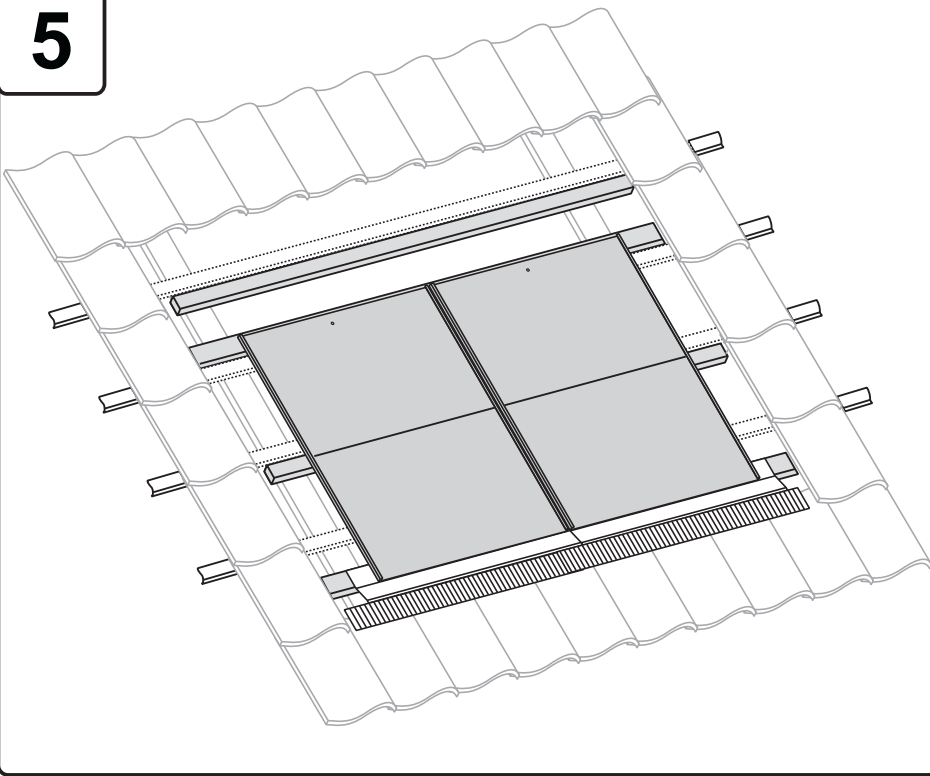

D Schiefer  
GB Slate

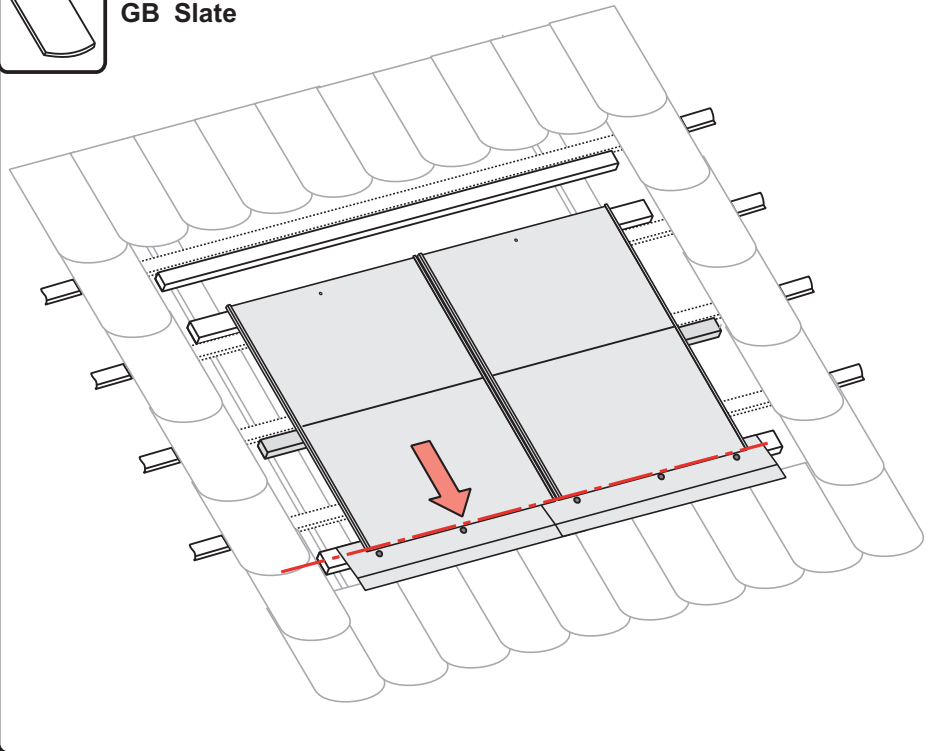

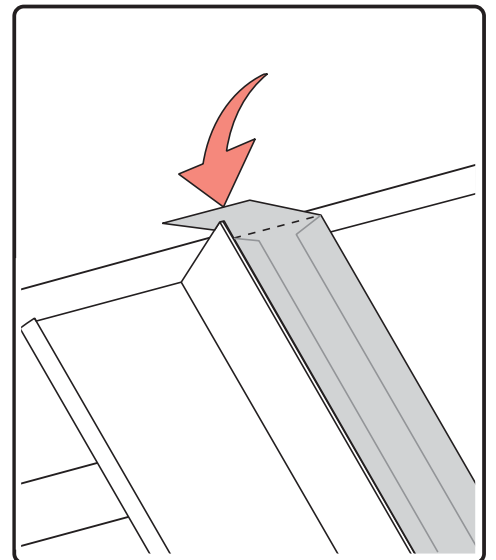
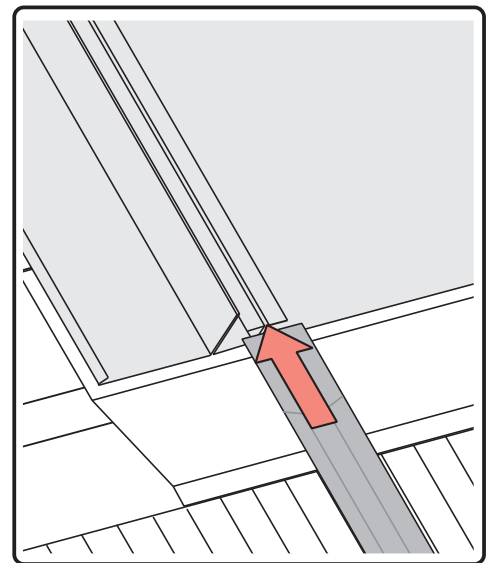
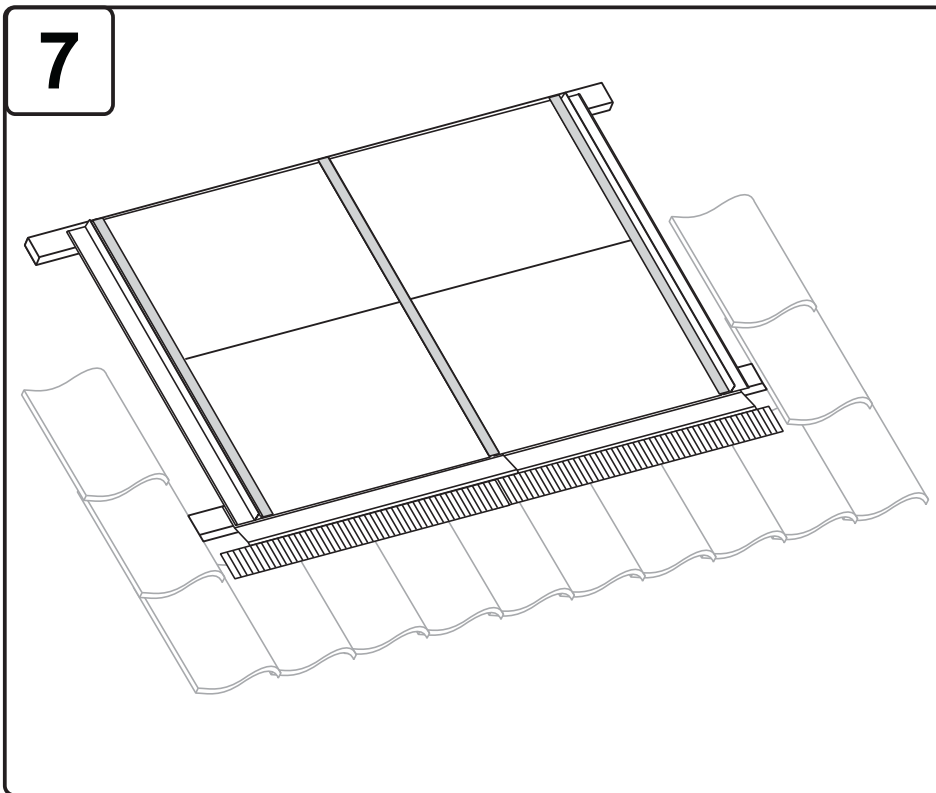
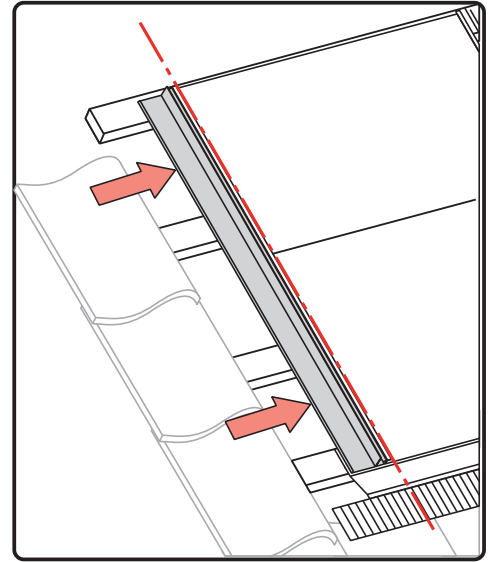
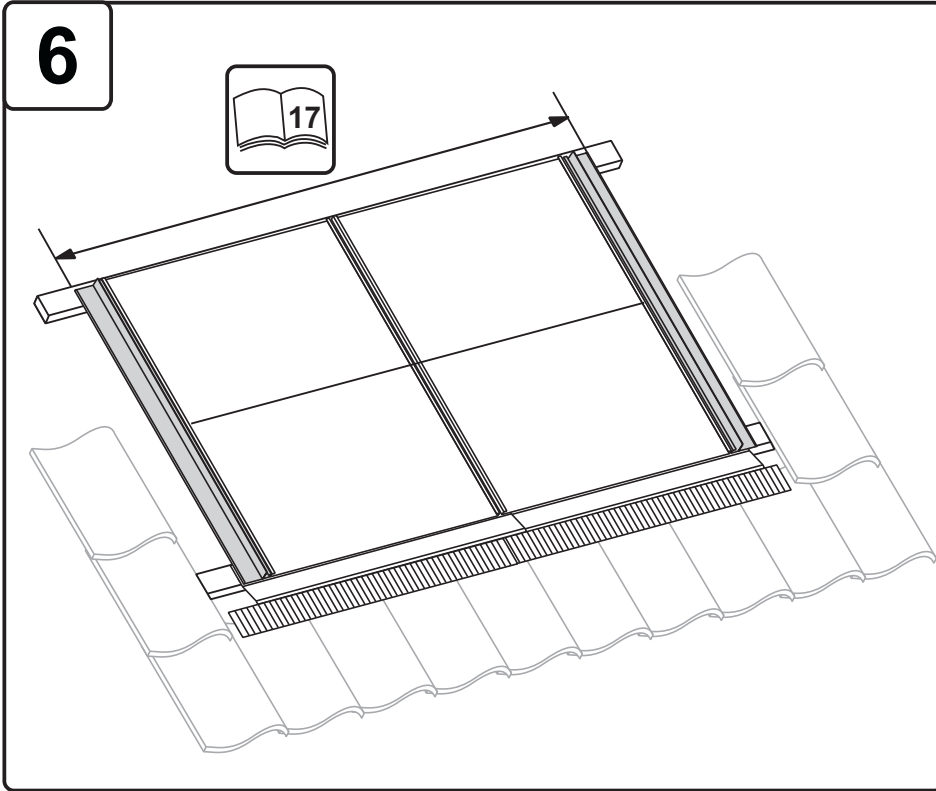
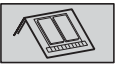

8

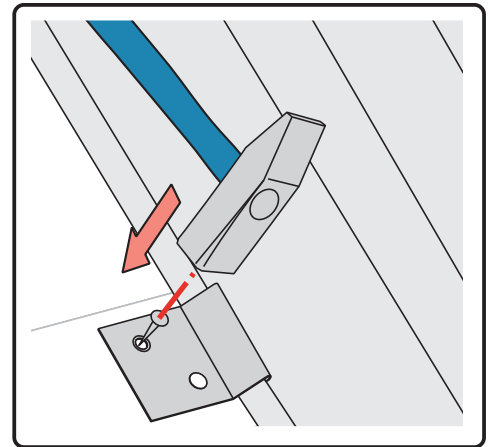
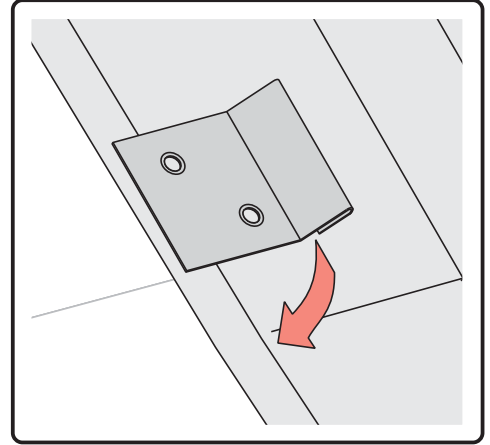
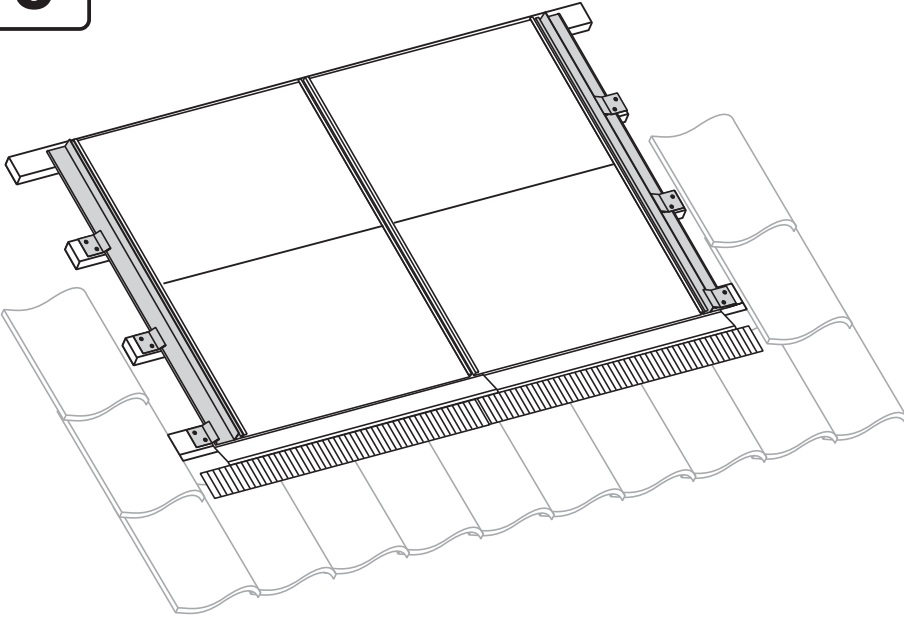

**i**

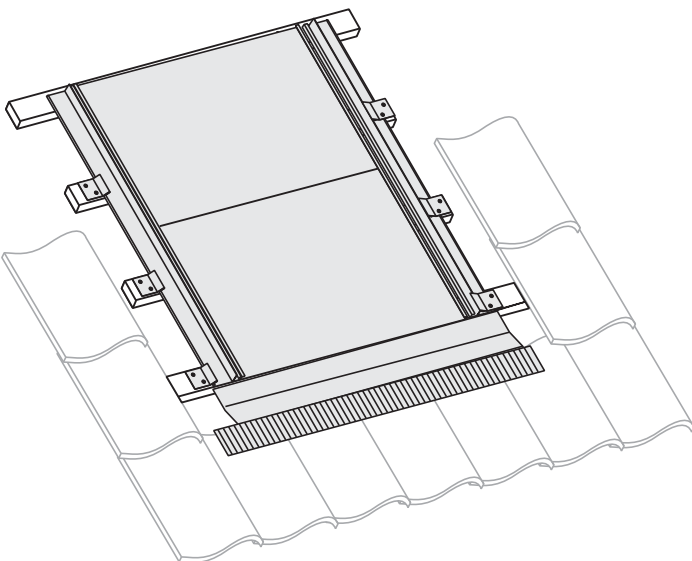

**i**

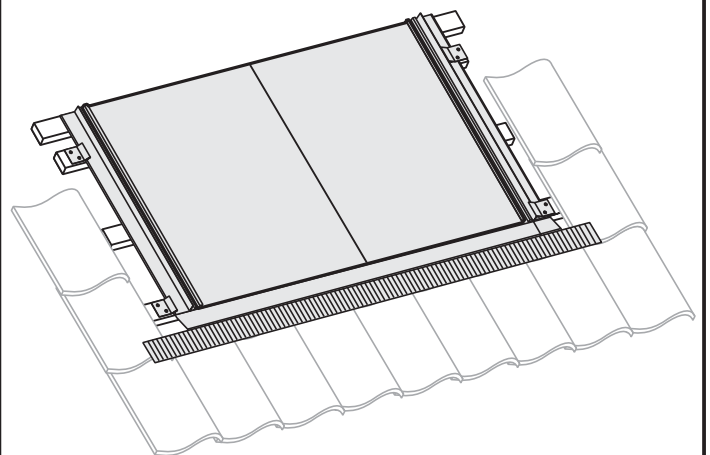

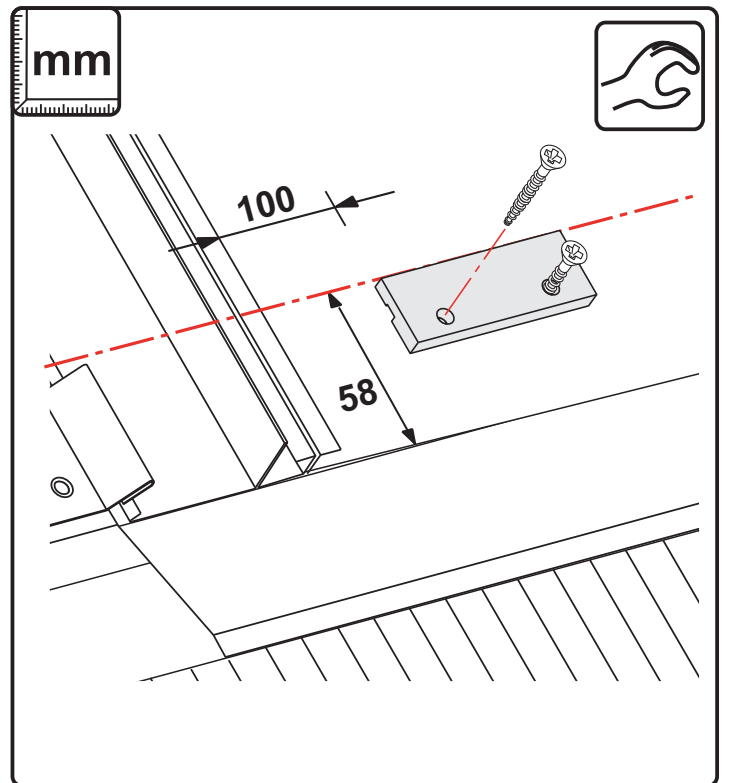
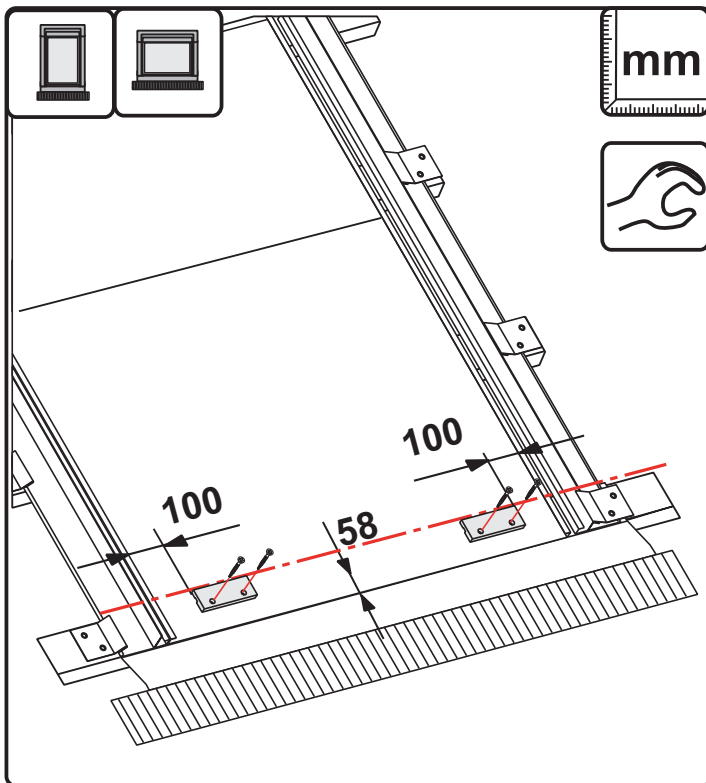
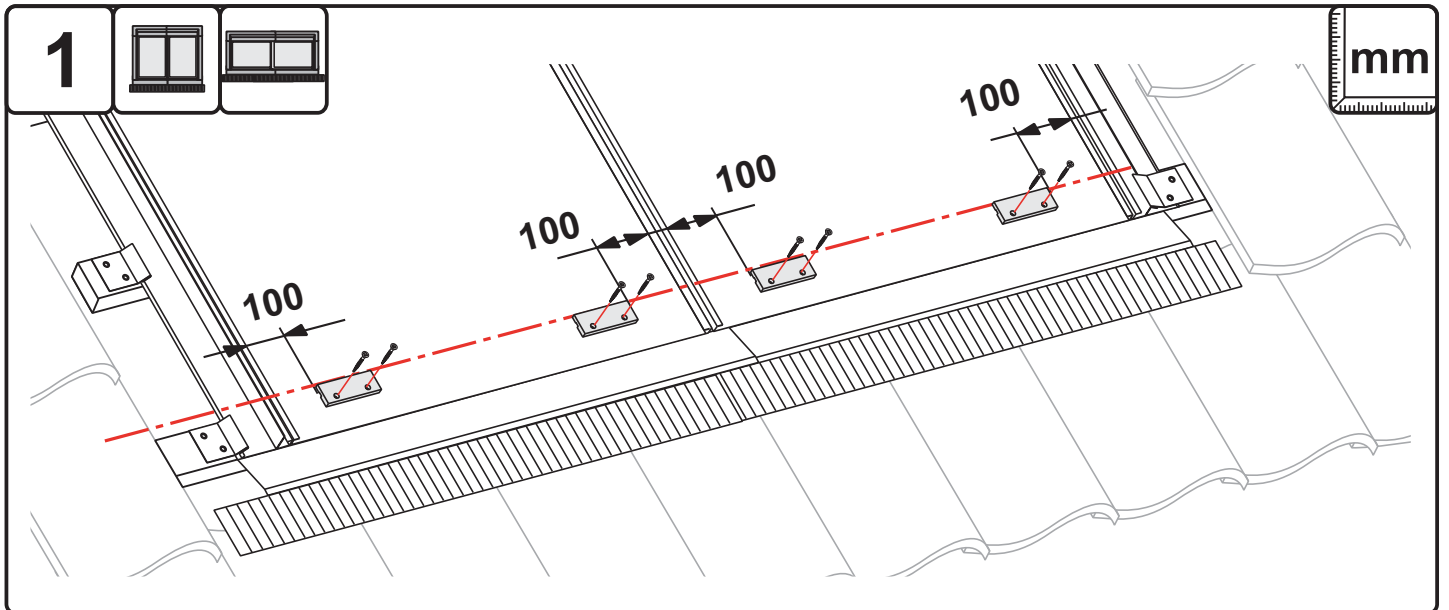
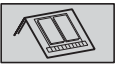



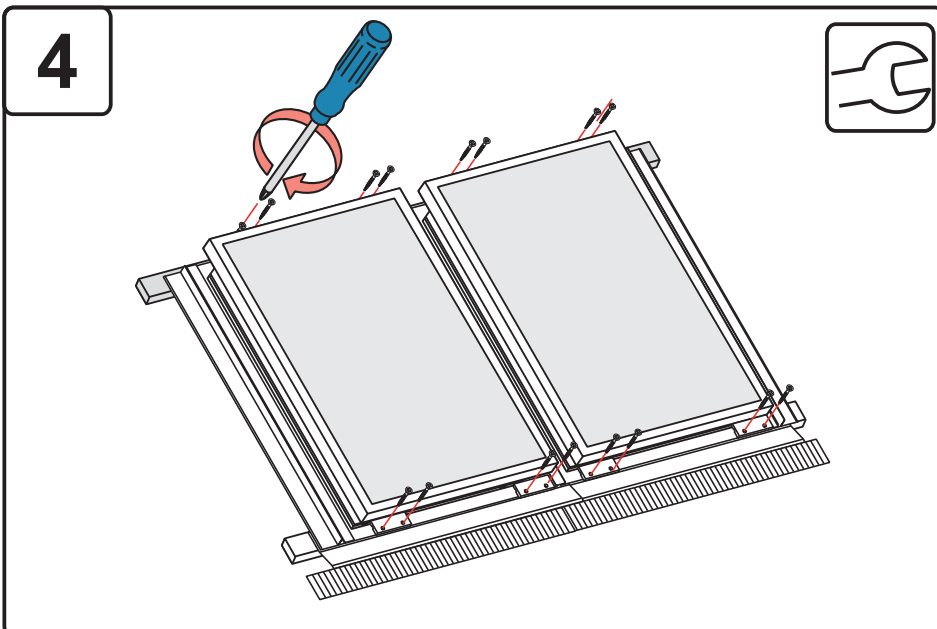
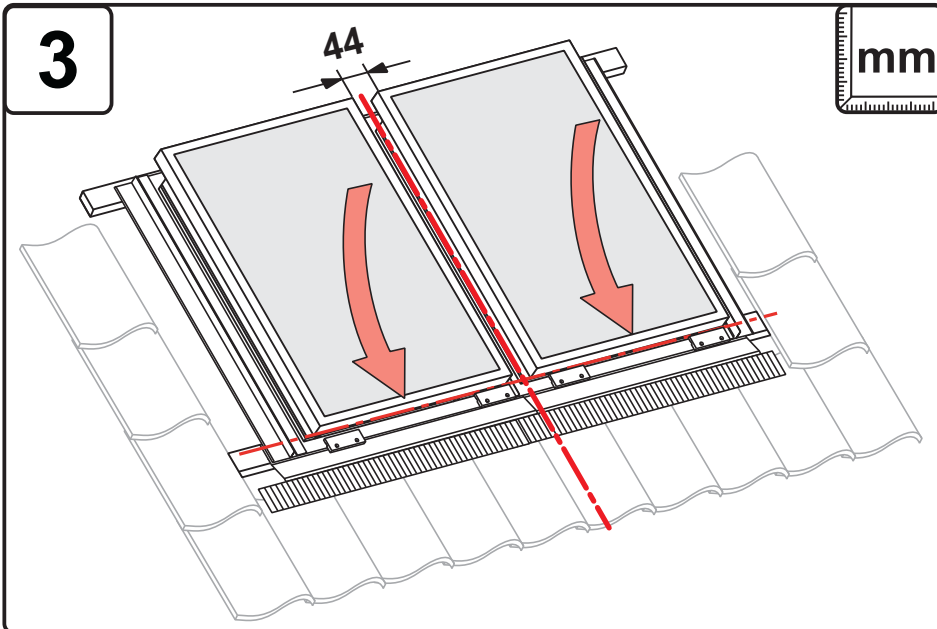
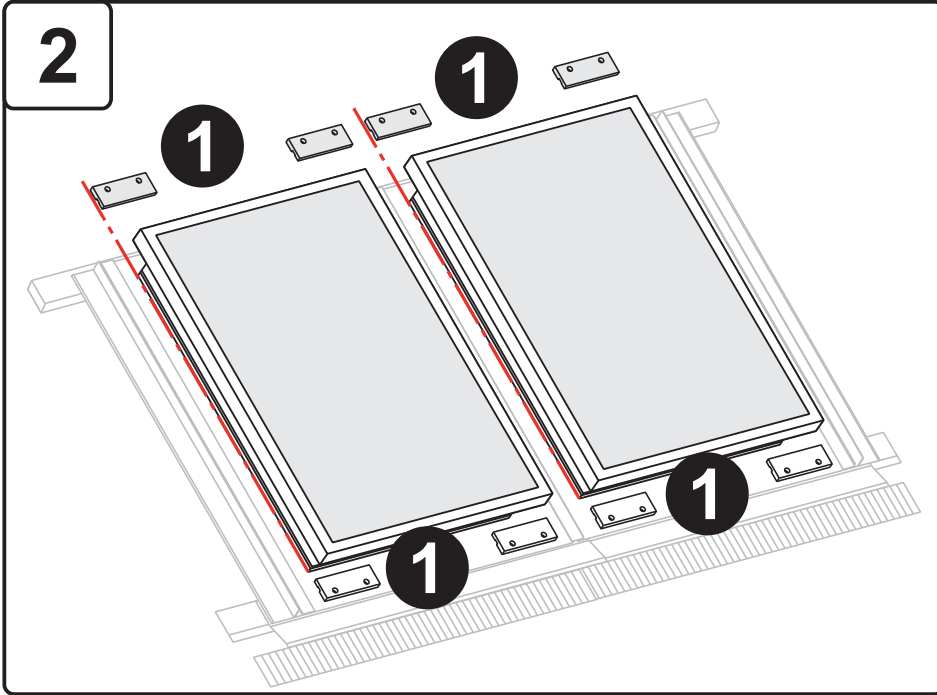
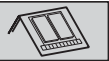

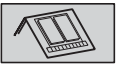

**i**

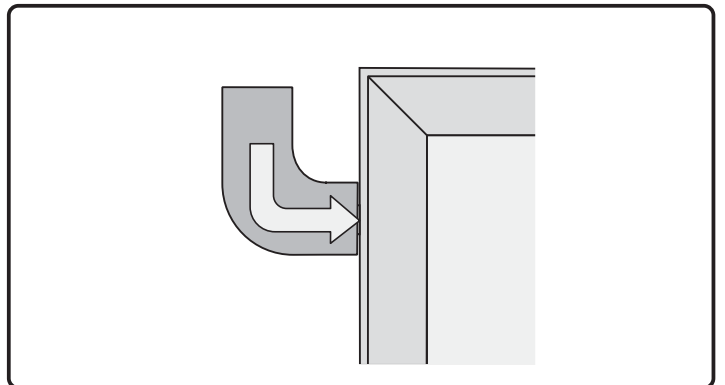
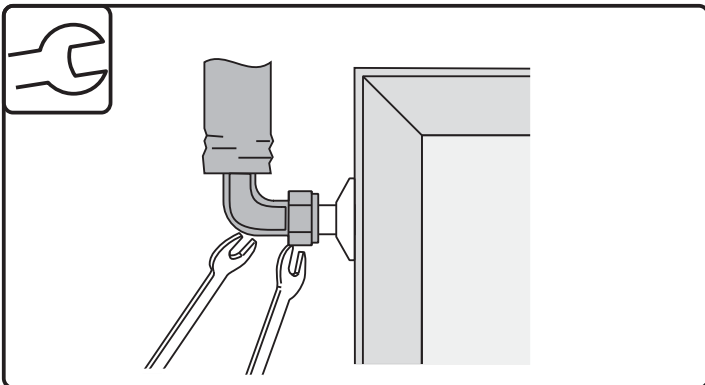
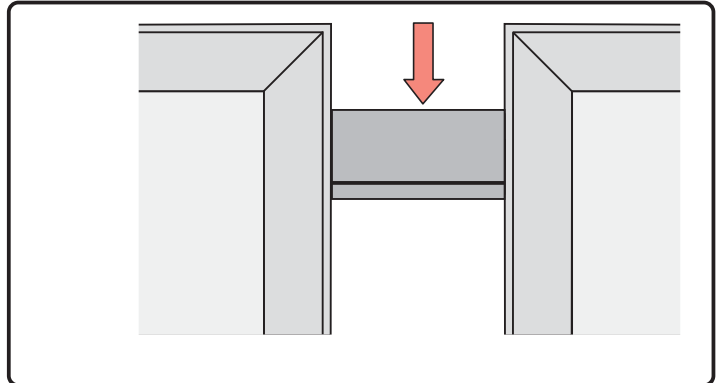
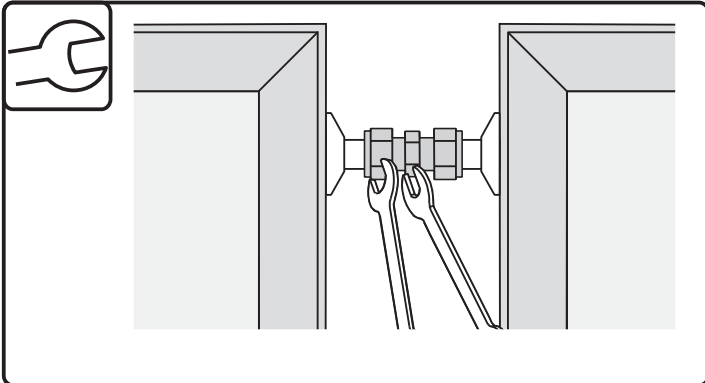
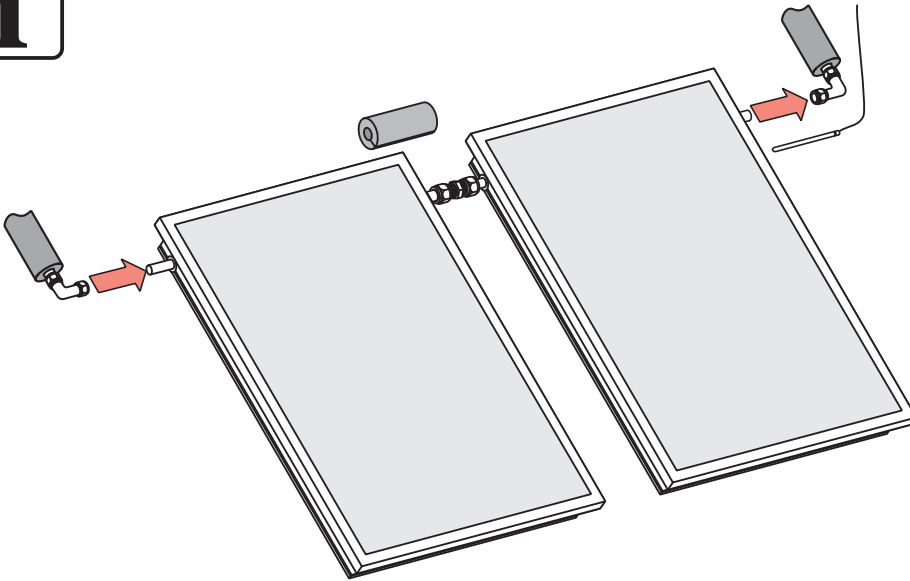

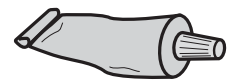
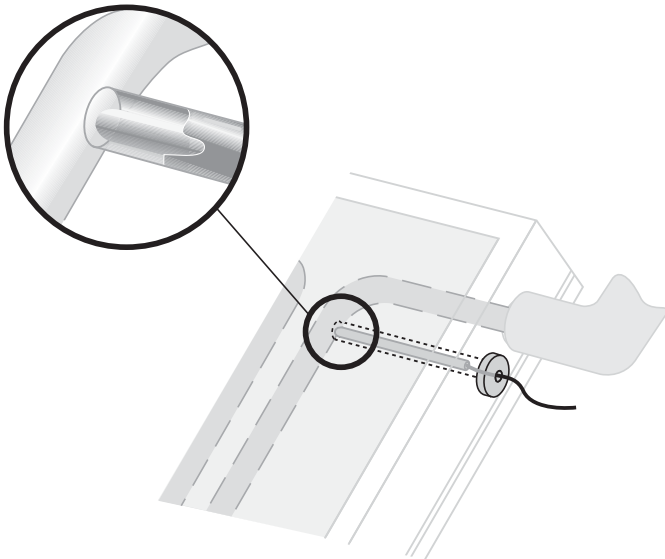
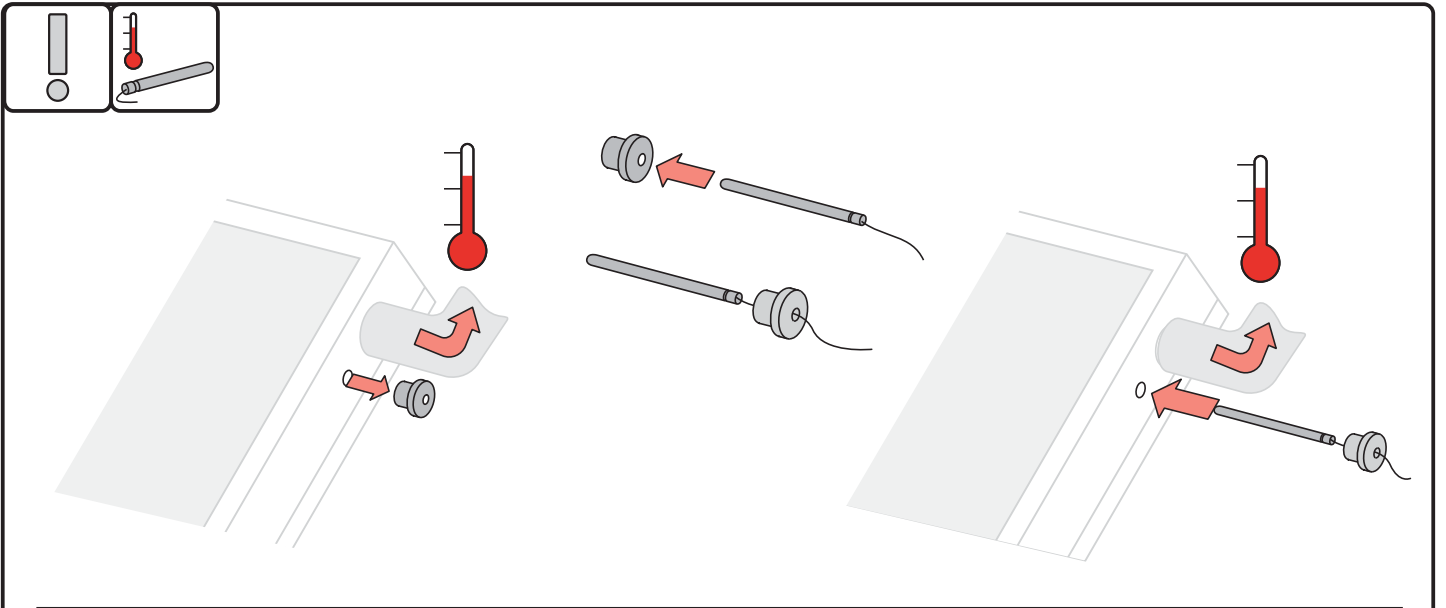
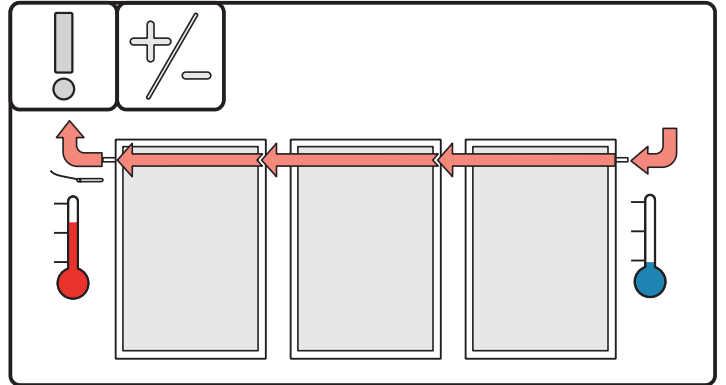
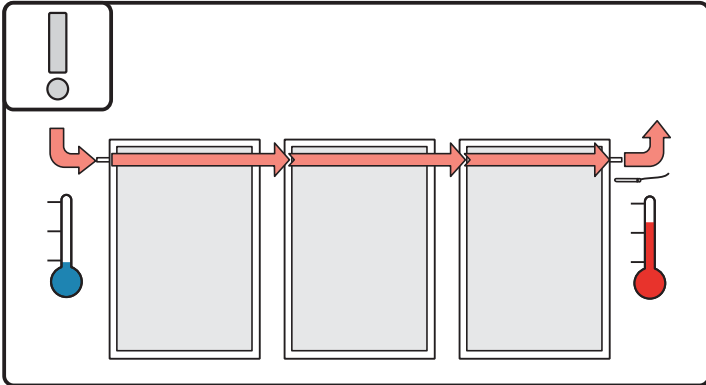

D Wärmeleitpaste  
GB Thermal conducting paste  
F Pâte thermoconductrice  
NL Warmtegeleidende pasta

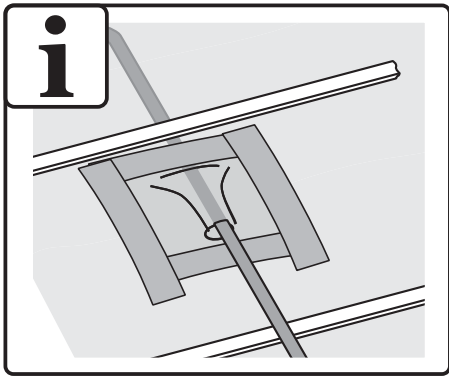
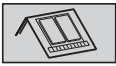

D Dachdurchführungen müssen systemgerecht und wasserdicht mit dem Unterdach verbunden werden.

GB Items penetrating the roof must be bonded to the roofing membrane in accordance with the relevant system so as to be waterproof.

F Les traversées de toit doivent être assemblées au sous-toit de manière étanche à l'eau et sous respect du système.

NL Dakdoorvoeringen moeten door een geschikt systeem en waterdicht met het dakbeschot verbonden worden.

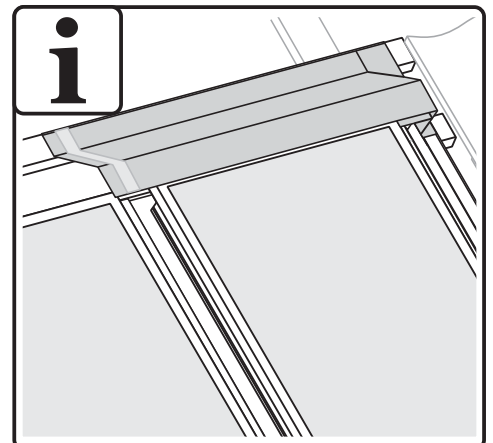
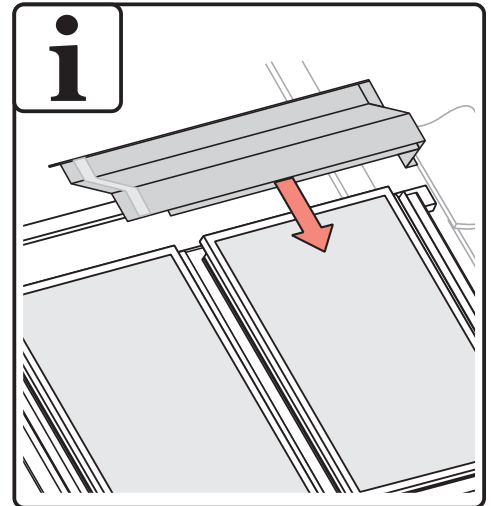
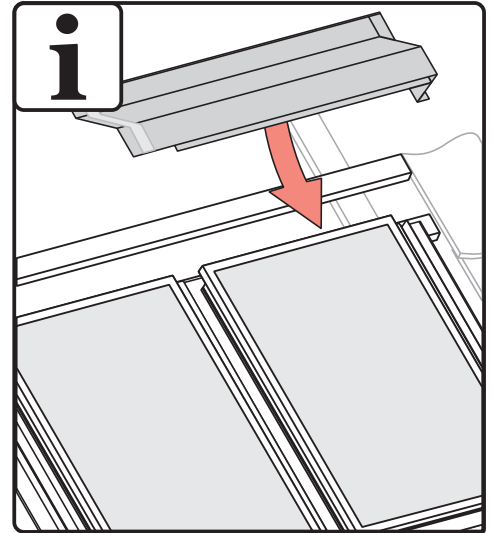
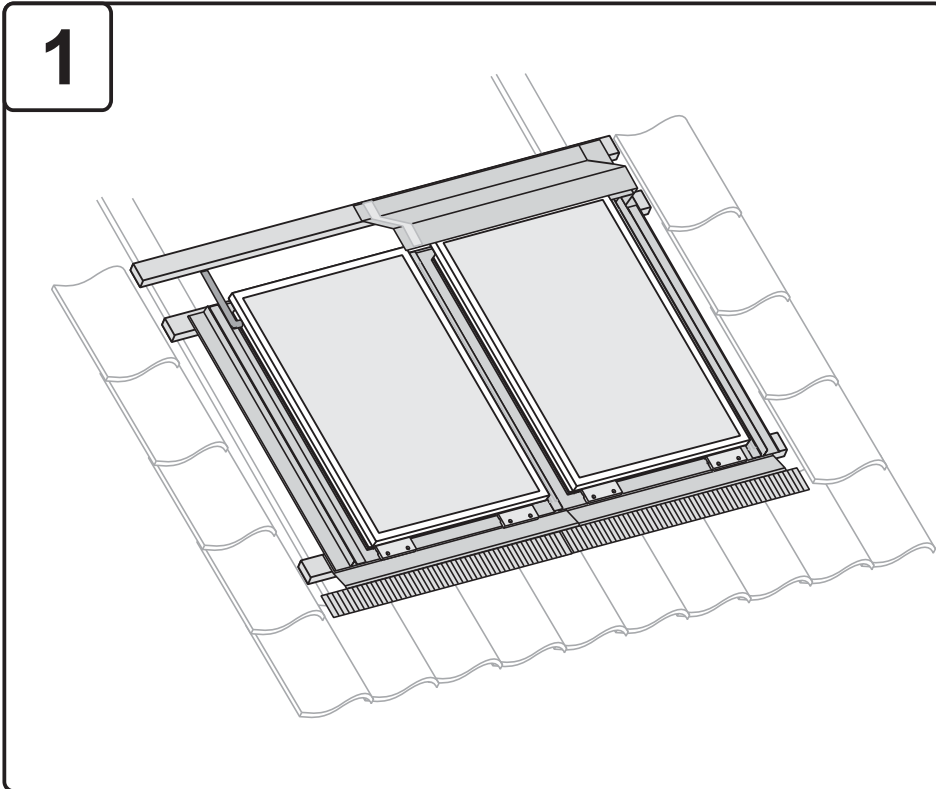

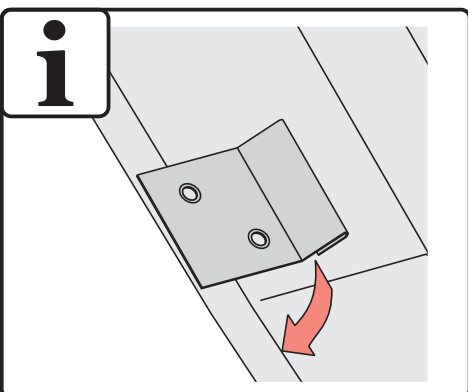
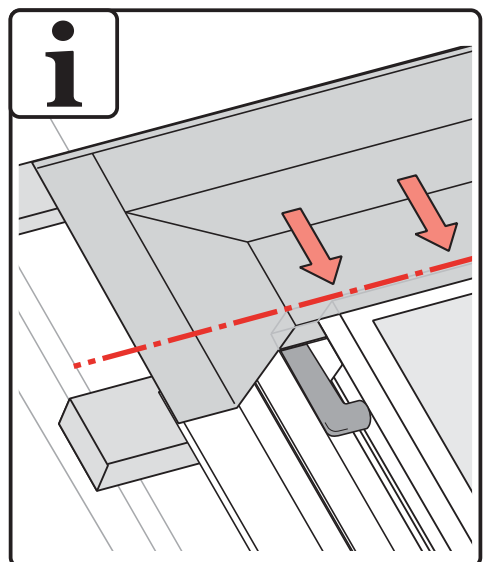
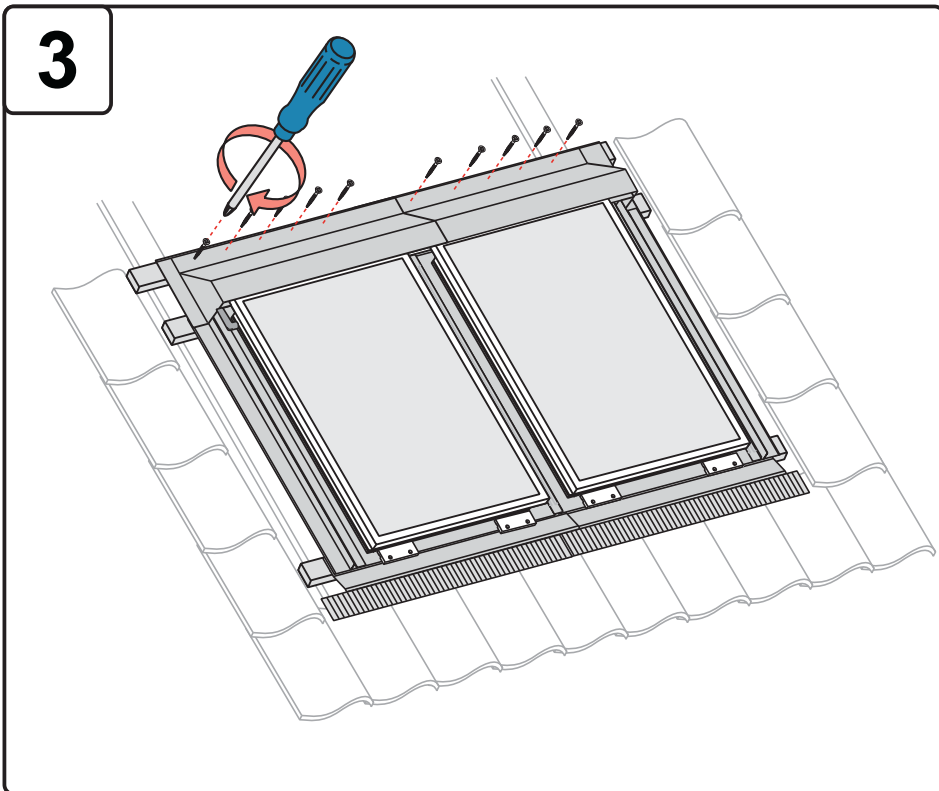
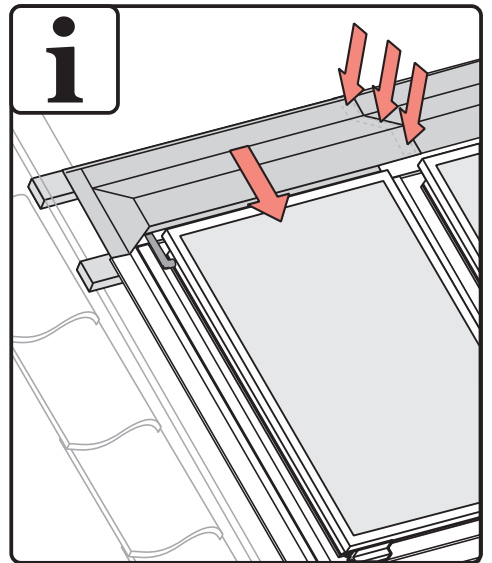
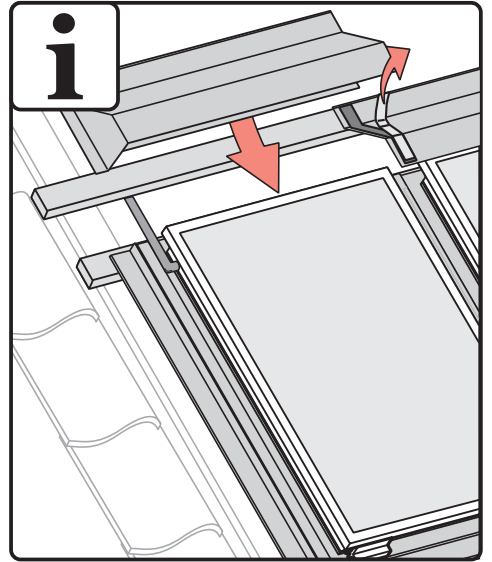
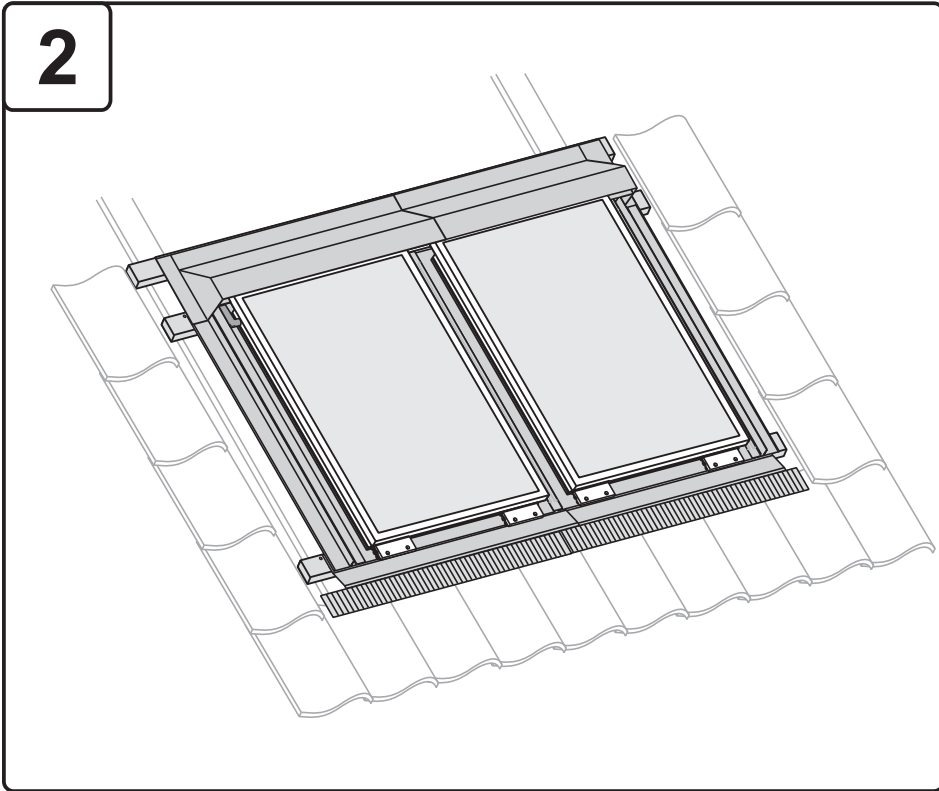

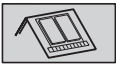

4

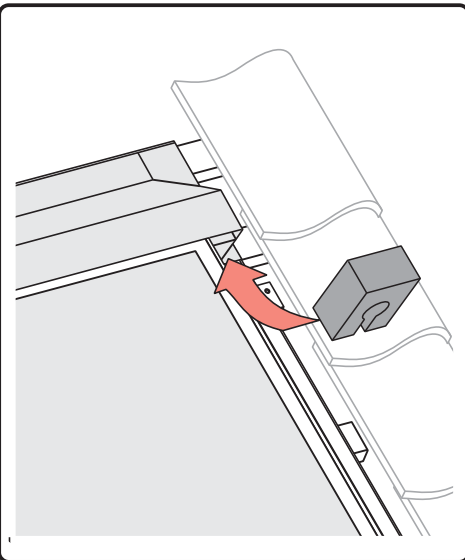
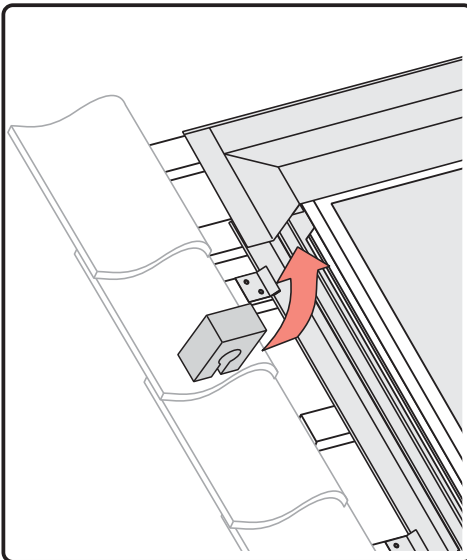
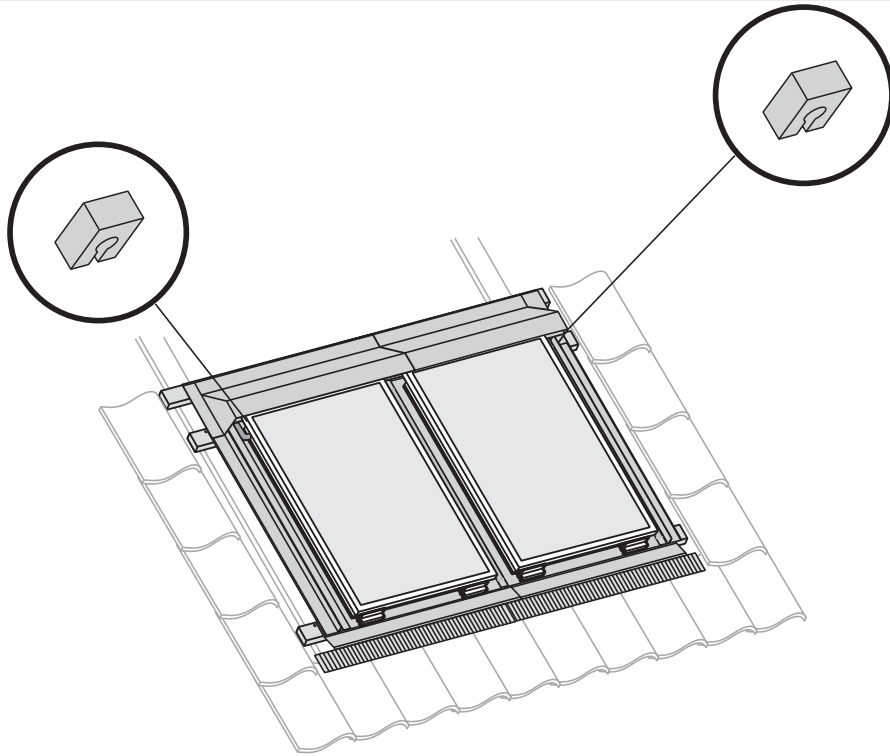

5

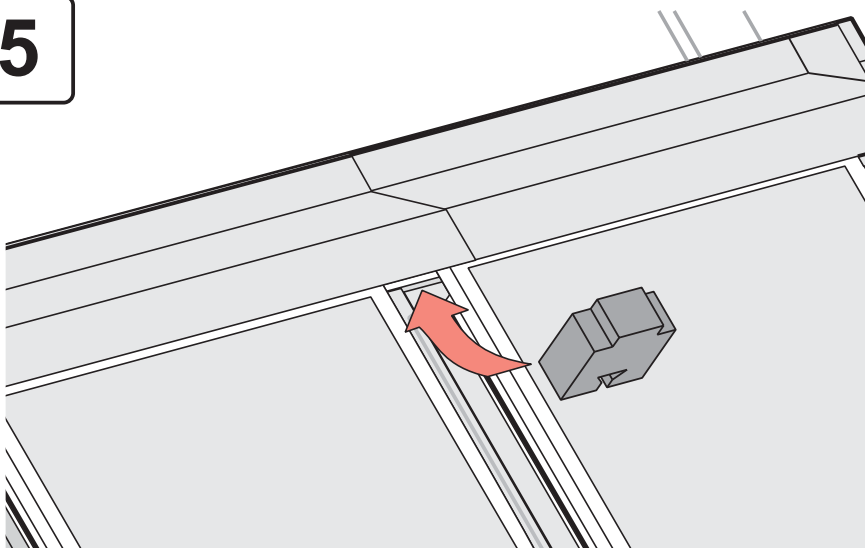

6

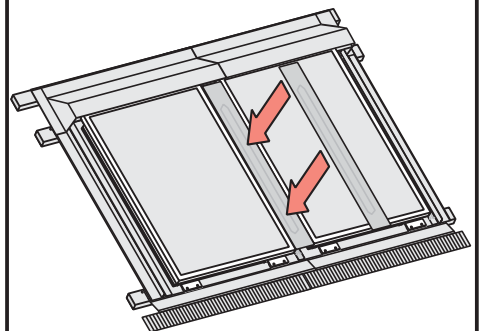
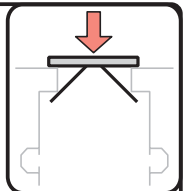

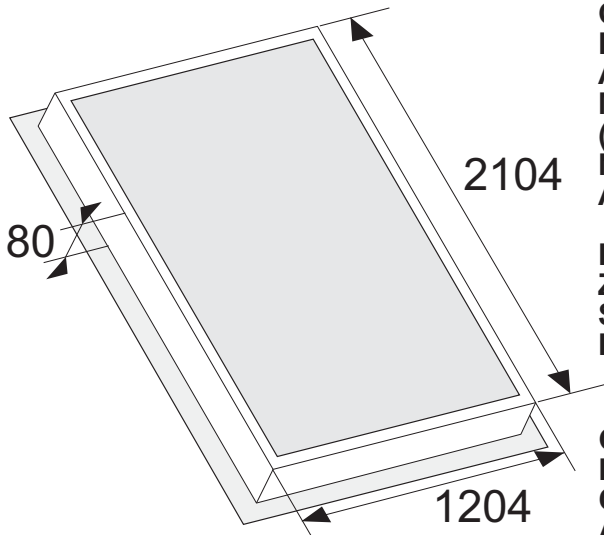
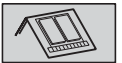

<b>D</b>		
Gewicht	=	44 kg
Kollektorfläche	=	2,53 m <sup>2</sup>
Absorberfläche	=	2,34 m <sup>2</sup>
Mindestvolumenstrom (V <sub>min</sub> )	=	2,5 l/min
Nennwärmeleistung	=	1,9 kW
Anschluss	=	2 Anschlussstutzen, 12 mm Cu-Rohr
Druckverlust (bei V <sub>min</sub> )	=	91 mbar
Zul. Betriebsüberdruck	=	10 bar
Stillstand-Temperatur	=	202 °C
Prüfung	=	nach DIN EN 12975

<b>GB</b>		
Dead load	=	44 kg
Collector surface	=	2,53 m <sup>2</sup>
Absorber surface	=	2,34 m <sup>2</sup>
min. volume flow rate(V <sub>min</sub> )	=	2,5 l/min
Thermal rating	=	1,9 kW
Connection	=	12 mm Cu-pipe
Pressure drop (V <sub>min</sub> )	=	91 mbar
max. Operating pressure	=	10 bar
Shutdown-temperature	=	202 °C
Test	=	following DIN EN 12975

<b>F</b>		
Poids	=	44 kg
Surface de capteurs	=	2,53 m <sup>2</sup>
Surface d'absorption	=	2,34 m <sup>2</sup>
Débit minimal (V <sub>min</sub> )	=	2,5 l/min
Puissance de chauffage nominale	=	1,9 kW
Connexion	=	2 Tubulures de, raccordement 12 mm Cu
Perte de pression (bei V <sub>min</sub> )	=	91 mbar
Pression de service autorisée	=	10 bar
Température d'arrêt	=	202 °C
Essai	=	selon DIN EN 12975

<b>NL</b>		
Gewicht	=	44 kg
Collectoroppervlak	=	2,53 m <sup>2</sup>
Absorberoppervlak	=	2,34 m <sup>2</sup>
Minimumvolumestroom (V <sub>min</sub> )	=	2,5 l/min
Nominaal warmtevermogen	=	1,9 kW
Aansluiting	=	2 aansluitstompen, 12 mm Cu-buis
Drukverlies (bij V <sub>min</sub> )	=	91 mbar
Toeg. bedrijfsoverdruk	=	10 bar
Stilstandtemperatuur	=	202 °C
Keuring	=	conform DIN EN 12975

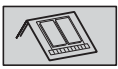

## D Inbetriebnahme

Nach der Kollektormontage und dem Anschluss der Hydraulik, kann die Anlage abgedrückt und befüllt werden.

Hierzu müssen sowohl die thermischen Gegebenheiten als auch die Besonderheiten der Anlage berücksichtigt werden.

Das Spülen und Befüllen darf nicht bei aufgeheizten Kollektoren erfolgen, da es zu Verbrühungen durch verdampfenden Wärmeträger kommen kann!

Deshalb darf die Befüllung, Einrichtung und Wartung der Anlage nur durch eine entsprechend autorisierte Fachkraft erfolgen.

Um einer Beschädigung der Anlage vorzubeugen, soll nur mit dem später verwendeten Wärmeträger abgedrückt werden.

### Wärmeträger

Um Frost- und Korrosionsschäden an Kollektoren und Anschlüssen zu vermeiden, darf die Solaranlage nur mit einem hochwertigen Wärmeträger (Propylenglykol- Wasser-Gemisch) befüllt werden.

Bei Verwendung der empfohlenen Fertigmischung besteht ein ausreichender Frostschutz bis ca.  $-24^{\circ}\text{C}$ .

### Unterweisung des Betreibers

Der Inbetriebnehmer hat den Anlagenbetreiber über die Funktion, Handhabung sowie den entsprechenden Wartungsintervallen der Anlage zu unterrichten.

Dem Anlagenbetreiber sind die Montage- und Bedienungsanleitungen zur Aufbewahrung auszuhändigen.

### Aufbewahrung der Montageanleitung

Die Montage- und Bedienungsanleitung ist dem Anlagenbetreiber auszuhändigen.

Dieser übernimmt die Aufbewahrung, damit die Anleitung im Bedarfsfall zur Verfügung steht.

## GB Commissioning

Following installation of the solar panels and hydraulic connection of the panels and pipework, the system can be filled.

When doing so, the thermal conditions and the particular features of the installation must be taken into account.

Rinsing and filling must not be carried out while the collectors are hot, as this could lead to scalding by heat transfer fluid vapour.

For this reason, the system may only be filled, commissioned and maintained by a suitably authorised technician.

To prevent damage to the system, hydraulic testing should take place using the heat transfer fluid to be subsequently used.

### Heat transfer fluid

In order to prevent frost and corrosion damage to the collectors and connectors, the system may only be filled with a high-quality heat transfer fluid (propylene glycol and water mix).

If the recommended ready-mixed fluid is used, this provides adequate frost protection to approx.  $-24^{\circ}\text{C}$ .

### Instructing the operator

The installer must instruct the system operator in the function, operation and required servicing intervals of the system.

The system operator must be handed the instructions for installation and use for safekeeping.

### Safekeeping of the installation instructions

The instructions for installation and use should be handed over to the system operator.

The operator is then responsible for their safekeeping so that they can be referred to in the future if necessary.



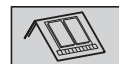

## F Mise en service

L'épreuve de pression et le remplissage de l'installation peuvent être effectués après le montage des capteurs et le raccordement de l'installation hydraulique.

Pour ce faire, il faut tenir compte des données thermiques ainsi que des particularités de l'installation.

Le rinçage et le remplissage d'un capteur chaud est interdit, cela pouvant causer des brûlures par l'évaporation de l'agent thermique!

Pour cette raison, l'installation ne doit être remplie, installée et entretenue que par un expert autorisé.

Afin d'éviter un endommagement de l'installation, l'épreuve de pression ne doit être effectuée qu'avec l'agent thermique utilisé ultérieurement.

### Agent thermique

Afin de protéger les capteurs et les raccords contre les dommages causés par le gel et la corrosion, l'installation solaire ne doit être remplie qu'avec un agent thermique de haute qualité (un mélange d'eau et de glycols propylènes).

En cas d'utilisation du mélange fini recommandé, la protection contre le gel est assurée jusqu'à une température d'environ -24 °C.

### Instruction de l'exploitant

L'installateur est tenu d'informer l'exploitant sur le fonctionnement, le maniement et les intervalles d'entretien correspondants de l'installation.

Les instructions de montage et de service doivent être remises à l'exploitant pour qu'il assure leur conservation.

### Conservation des instructions de montage

Les instructions de montage et de service doivent être remises à l'exploitant de l'installation.

Celui-ci les prendra en charge et les conservera pour qu'elles soient disponibles en cas de besoin.

## NL Inbedrijfstelling

Na de collectormontage en de aansluiting van de hydraulica kan de installatie op afdichting gecontroleerd en gevuld worden.

Hiervoor moet er rekening gehouden worden met zowel de thermische omstandigheden als de bijzonderheden van de installatie.

Het spoelen en vullen mag niet bij opgewarmde collectoren plaatsvinden omdat het tot brandwonden door verdampende warmtedragers kan komen!

Daarom mogen de vulling, de installatie en het onderhoud van de installatie uitsluitend door een op gepaste wijze gemachtigde, geschoolde arbeidskracht doorgevoerd worden.

Om een beschadiging van de installatie te voorkomen, mag er enkel met de later gebruikte warmtedrager op afdichting gecontroleerd worden.

### Warmtedrager

Om schade aan collectoren en aansluitingen door vorst en corrosie te vermijden, mag de zonne-installatie enkel met een hoogwaardige warmtedrager (mengsel van propyleenglycol met water) gevuld worden.

Bij gebruikmaking van het aanbevolen afgewerkte mengsel bestaat er een toereikende bescherming tegen vorst tot ca. -24 °C.

### Onderrichting van de exploitant

De inbedrijfsteller dient de exploitant van de installatie van de werking, de hantering en ook van de passende onderhoudsintervallen van de installatie op de hoogte te brengen.

Aan de exploitant van de installatie dienen de montage-instructies en gebruiksaanwijzingen met het oog op bewaring overhandigd te worden.

### Bewaring van de montage-instructies

De montage-instructies en gebruiksaanwijzing dienen aan de exploitant van de installatie overhandigd te worden.

Deze laatste neemt de bewaring op zich opdat de handleiding zo nodig ter beschikking staat.





