



Montage- und Bedienungsanleitung

Pumpensets zur Rücklaufhochhaltung mit Stellmotor



Installation and Operation Instructions

Pump sets for return flow temperature maintenance with actuator



Notice de montage et d'utilisation

Kits de pompe pour le maintien de la température de retour avec servomoteur



Manual de instrucciones

Kits de bomba para mantenimiento de la temperatura retorno con accionador



Istruzioni per il montaggio e per l'uso

Set di pompe per l'innalzamento della temperatura di ritorno con servomotore



Art. Nr. / Item no. / N° d'article / N° de art. / Cod. art. 999608x-mub-ml

Version / Versión / Versione V09

Technische Änderungen vorbehalten!

We reserve the right to make technical changes without notice!

Sous réserve de modifications techniques !

¡Sujeto a modificaciones técnicas!

Con riserva di modifiche tecniche!

PAW GmbH & Co. KG

Böcklerstraße 11

D-31789 Hameln, Germany

Printed in Germany – Copyright by PAW GmbH & Co. KG

Inhaltsverzeichnis

1	Allgemeines	4
1.1	Geltungsbereich der Anleitung	4
1.2	Bestimmungsgemäße Verwendung.....	4
2	Sicherheitshinweise	5
3	Produktbeschreibung	6
3.1	Ausstattung	6
3.2	Funktion	7
4	Montage und Installation [Fachmann]	7
4.1	Montage des Stellmotors [Fachmann]	8
4.1.1	Stellmotor SR2 - DN 20 / SR5 – DN 25 + DN 32 / SR10 - DN 40 + DN 50	8
5	Technische Daten DN 20 - DN 50	10

1 Allgemeines



Lesen Sie diese Anleitung vor der Installation und Inbetriebnahme sorgfältig durch.
Bewahren Sie diese Anleitung zum späteren Gebrauch in der Nähe der Anlage auf.

1.1 Geltungsbereich der Anleitung

Diese Anleitung beschreibt die Funktion, Installation, Inbetriebnahme und Bedienung der Pumpensets DN 20 - DN 50 für die Rücklaufhochhaltung mit Stellmotor.

Für andere Komponenten der Anlage, wie z. B. die Pumpe, den Regler oder den Stellmotor, beachten Sie bitte die Anleitungen des jeweiligen Herstellers.

Die mit [Fachmann] bezeichneten Kapitel richten sich ausschließlich an den Fachhandwerker.

1.2 Bestimmungsgemäße Verwendung

Das Pumpenset darf nur in Heizungskreisen unter Berücksichtigung der in dieser Anleitung angegebenen technischen Grenzwerte verwendet werden.

Das Pumpenset darf **nicht** in Trinkwasseranwendungen eingesetzt werden.

Die bestimmungswidrige Verwendung des Pumpensets führt zum Ausschluss jeglicher Haftungsansprüche.

Das Produkt entspricht den relevanten Richtlinien und ist daher mit dem CE-Kennzeichen versehen. Die Konformitätserklärung kann beim Hersteller angefordert werden.

Verwenden Sie ausschließlich PAW-Zubehör in Verbindung mit dem Pumpenset.

Die Verpackungsmaterialien bestehen aus recycelbaren Materialien und können dem normalen Wertstoffkreislauf wieder zugeführt werden.

2 Sicherheitshinweise

Die Installation und Inbetriebnahme sowie der Anschluss der elektrischen Komponenten setzen Fachkenntnisse voraus, die einem anerkannten Berufsabschluss als Anlagenmechaniker/in für Sanitär-, Heizungs- und Klimatechnik bzw. einem Beruf mit vergleichbarem Kenntnisstand entsprechen [Fachmann].

Bei der Installation und Inbetriebnahme muss folgendes beachtet werden:

- Einschlägige regionale und überregionale Vorschriften
- Unfallverhütungsvorschriften der Berufsgenossenschaft
- Anweisungen und Sicherheitshinweise dieser Anleitung

! VORSICHT	
	<p>Personen- und Sachschaden!</p> <p>Das Pumpenset ist nur geeignet für den Einsatz in Heizungskreisen mit Heizungswasser gemäß VDI 2035 / Ö-Norm H 5195-1.</p> <p>Das Pumpenset darf nicht in Trinkwasseranwendungen eingesetzt werden.</p>

ACHTUNG

Sachschaden durch Mineralöle!

Mineralölprodukte beschädigen die EPDM-Dichtungselemente nachhaltig, wodurch die Dichteigenschaften verloren gehen. Für Schäden, die durch derartig beschädigte Dichtungen entstehen, übernehmen wir weder eine Haftung noch leisten wir Garantieersatz.

- Vermeiden Sie unbedingt, dass EPDM mit mineralöhlhaltigen Substanzen in Kontakt kommt.
- Verwenden Sie ein mineralölfreies Schmiermittel auf Silikon- oder Polyalkylenbasis, wie z. B. Unisilikon L250L und Syntheso Glep 1 der Firma Klüber oder Silikonspray.

3 Produktbeschreibung

Die Pumpensets sind vormontierte Armaturengruppen für Heizungskreise. Die Pumpe kann durch die Kugelhähne abgesperrt werden und kann so einfach gewartet werden, ohne dass das Wasser im Heizungskreis abgelassen werden muss.

3.1 Ausstattung

DN 20

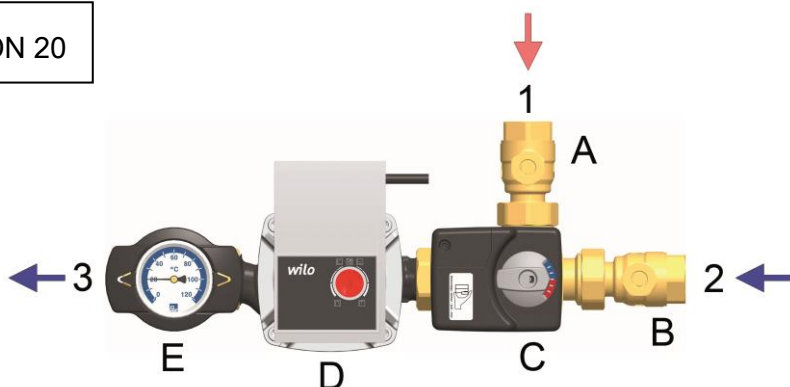

DN 25 - DN 50

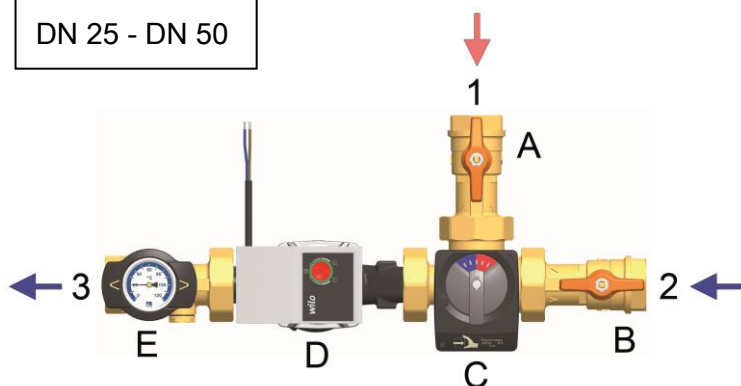

- 1 Bypass (vom Kesselvorlauf)
- 2 Rücklauf vom Pufferspeicher
- 3 Rücklauf zum Kessel

- A Kugelhahn Vorlauf
- B Kugelhahn Rücklauf
- C 3-Wege-Ventil mit Stellmotor, DN 25 + DN 32 = 5 Nm, DN 40 + DN 50 = 10 Nm
- D Heizungspumpe
- E Kugelhahn Rücklauf
- F* Pumpensets DN 25 und DN 32, mit optionaler Isolierung (abhängig von Pumpenversion)

3.2 Funktion

Pumpensets zur Rücklaufhochhaltung mit Stellmotor

Mit Hilfe des Pumpensets wird eine Unterschreitung des Taupunktes im Kessel und damit die Kesselversottung verhindert.

Das Pumpenset wird zwischen dem Pufferspeicher und dem Kessel montiert. Der Stellmotor wird von einem externen Regler angesteuert. Der Stellmotor öffnet das 3-Wege-Ventil erst, wenn der Kesselkreis die eingestellte Öffnungstemperatur erreicht hat. Dann steht die Leistung der Pumpe zur Beladung des Speichers zur Verfügung.

Einsatzgebiete:

- für Wärmequellen, bei denen eine Rücklaufhochhaltung notwendig ist, wie z.B. Festbrennstoffkessel, Holzfeuerungsanlagen und Kamine

4 Montage und Installation [Fachmann]

ACHTUNG

Sachschaden

Um Schäden an der Anlage zu verhindern, muss der Montageort trocken, tragsicher und frostfrei sein. Montieren Sie die Pumpe immer im Rücklauf zum Kessel, da sie durch die hohen Vorlauftemperaturen beschädigt werden könnte.

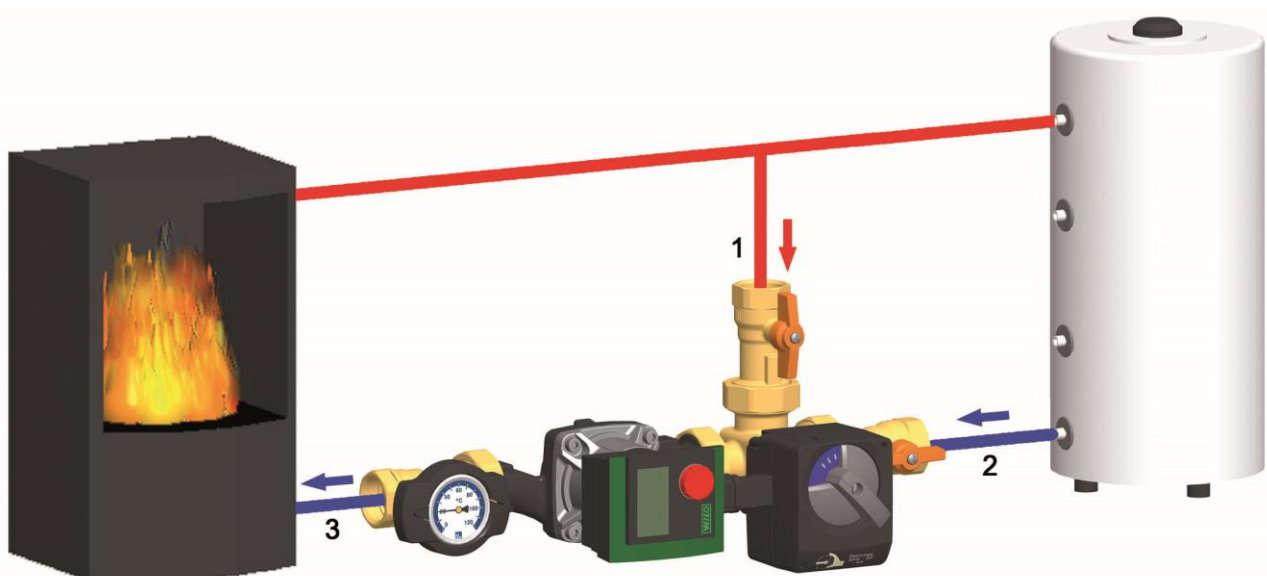

4.1 Montage des Stellmotors [Fachmann]

4.1.1 Stellmotor SR2 - DN 20 / SR5 – DN 25 + DN 32 / SR10 - DN 40 + DN 50

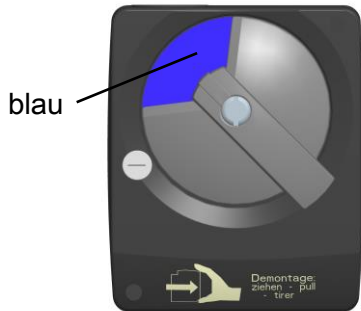

1. Stellen Sie den Wahlschalter am Stellmotor auf Handbetrieb. Nur dann kann der Verstellgriff des Stellantriebs von Hand betätigt werden.

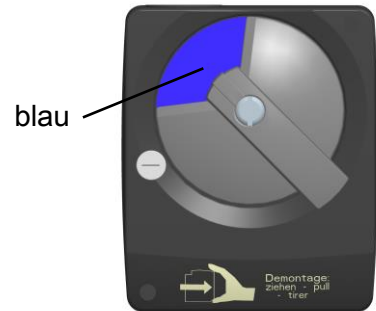

2. Drehen Sie den Verstellgriff nach links in die Position „blau“.

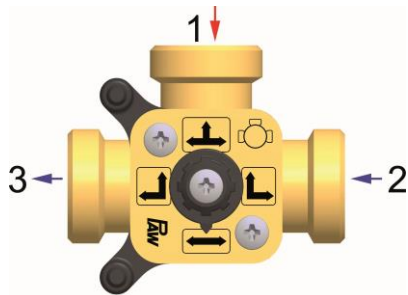

3. Drehen Sie den Drehknopf des 3-Wege-Ventils so, dass die Nase nach unten bzw. nach links auf \leftrightarrow zeigt.

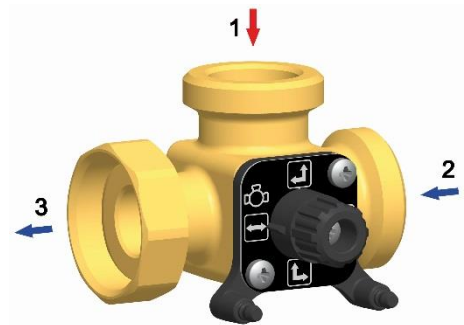

4. Drehen Sie den Stellmotor wie abgebildet und rasten Sie ihn auf das 3-Wege-Ventil.

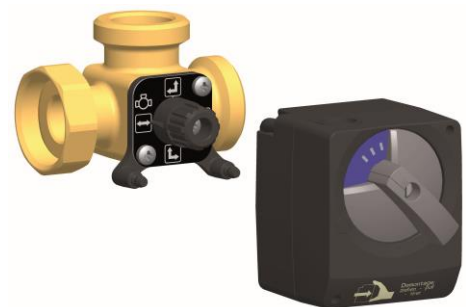



5. Schließen Sie den Stellmotor an den Regler an.

Wenn der Motor aktiviert wird, dreht er 90° im Uhrzeigersinn!



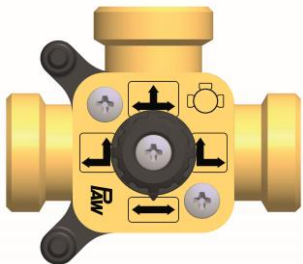
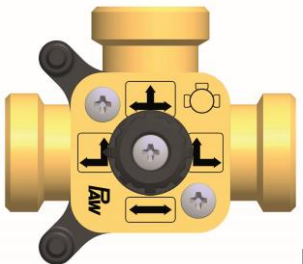
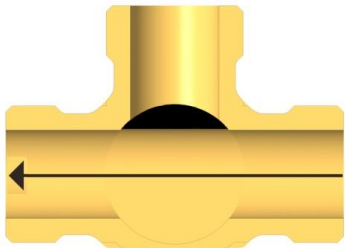
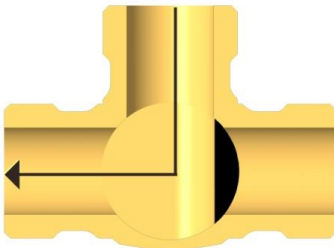

6. Stellen Sie am Stellmotor den Automatikbetrieb ein. Der Stellmotor ist jetzt betriebsbereit.

Wenn der Motor aktiviert wird, dreht er 90° im Uhrzeigersinn!

Stellmotor SR2 - DN 20

100 % Rücklauf	100 % aus dem Kesselvorlauf
 <p>Position „blau“</p>	 <p>Position „rot“</p>
 <p>Nase zeigt auf ↔</p>	 <p>Nase zeigt auf ↗</p>
	

Stellmotor SR5 – DN 25 + DN 32 / SR10 - DN 40 + DN 50

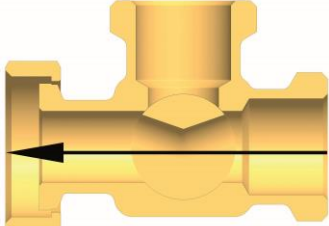
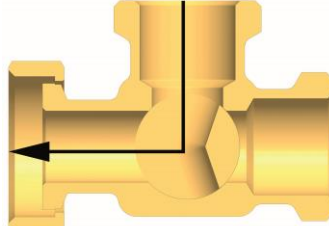
100 % Rücklauf	100 % aus dem Kesselvorlauf
 <p>Position „blau“</p>	 <p>Position „rot“</p>
 <p>Nase zeigt auf ↔</p>	 <p>Nase zeigt auf ↗</p>
	

5 Technische Daten DN 20 - DN 50

Pumpensets	DN 20	DN 25	DN 32	DN 40	DN 50
Abmessungen					
Einbauhöhe	134 mm	187 mm	217 mm	266 mm	296 mm
Einbaulänge	359 mm	437 mm	497 mm	735 mm	792 mm
Anschlüsse	¾" IG	1" IG	1¼" IG	1½" IG	2" IG
Hydraulik					
Max. Druck	6 bar	6 bar	6 bar	6 bar	6 bar
Max. Temperatur	110 °C	110 °C	110 °C	110 °C	110 °C
K _{vs} -Wert [m³/h]	5,45	10	16	23	25
Werkstoffe					
Armaturen	Messing				
Dichtungen	EPDM / NBR				

Lieferumfang und Druckverlust- und Pumpenkennlinien: siehe letzte Seiten dieser Anleitung.

Contents

1	General information	12
1.1	Scope of these instructions	12
1.2	Designated use	12
2	Safety instructions	13
3	Product description	14
3.1	Equipment.....	14
3.2	Function	15
4	Assembly and installation [specialist]	15
4.1	Assembly of the actuator [specialist]	16
4.1.1	Actuator SR2 - DN 20 / SR5 – DN 25 + DN 32 / SR10 - DN 40 + DN 50	16
5	Technical data DN 20 - DN 50	18

1 General information



Carefully read these instructions before installation and commissioning.
Save these instructions in the vicinity of the installation for future reference.

1.1 Scope of these instructions

These instructions describe the installation, commissioning, function and operation of the pump sets DN 20 - DN 50 for return flow temperature maintenance with actuator. For other components of the heating system, such as the pump, the controller or the actuator, please observe the instructions of the corresponding manufacturer.

The chapters called [specialist] are intended for specialists only.

1.2 Designated use

The pump sets may only be used in hydronic heating closed-loop systems taking into consideration the technical limit values indicated in these instructions.

The pump set must **not** be used in domestic water applications.

Improper usage excludes any liability claims.

The product complies with the relevant directives and is therefore labelled with the CE mark.

The Declaration of Conformity is available upon request. Please contact the manufacturer.

Only use PAW accessories with the pump set.



The wrapping materials are made of recyclable materials and can be disposed of with recyclable materials.

2 Safety instructions

The installation and commissioning as well as the connection of electrical components require technical knowledge commensurate with a recognised vocational qualification as a fitter for plumbing, heating and air conditioning technology, or a profession requiring a comparable level of knowledge [specialist].

The following must be observed during installation and commissioning:

- relevant local and national regulations
- accident prevention regulations of the professional association
- instructions and safety instructions mentioned in this manual

	CAUTION
	<p>Personal injury and damage to property!</p> <p>The pump set must only be used in heating circuits filled with heating water according to VDI 2035 / Ö-Norm H 5195-1.</p> <p>The pump set must not be used in domestic hot water applications.</p>

NOTICE

Material damage due to mineral oils!

Mineral oil products cause lasting damage to seals made of EPDM, whereby the sealant properties get lost. We do not assume liability nor provide warranty for damage to property resulting from sealants damaged in this way.

- It is imperative to avoid that EPDM gets in contact with substances containing mineral oils.
- Use a lubricant based on silicone or polyalkylene and free of mineral oils, such as Unisilikon L250L and Syntheso Glep 1 of the Klüber company or a silicone spray.

3 Product description

The pump sets are preassembled fitting groups for hydronic heating closed-loop systems. The pump can be isolated by means of the ball valves and can thus be maintained without draining of the system.

3.1 Equipment

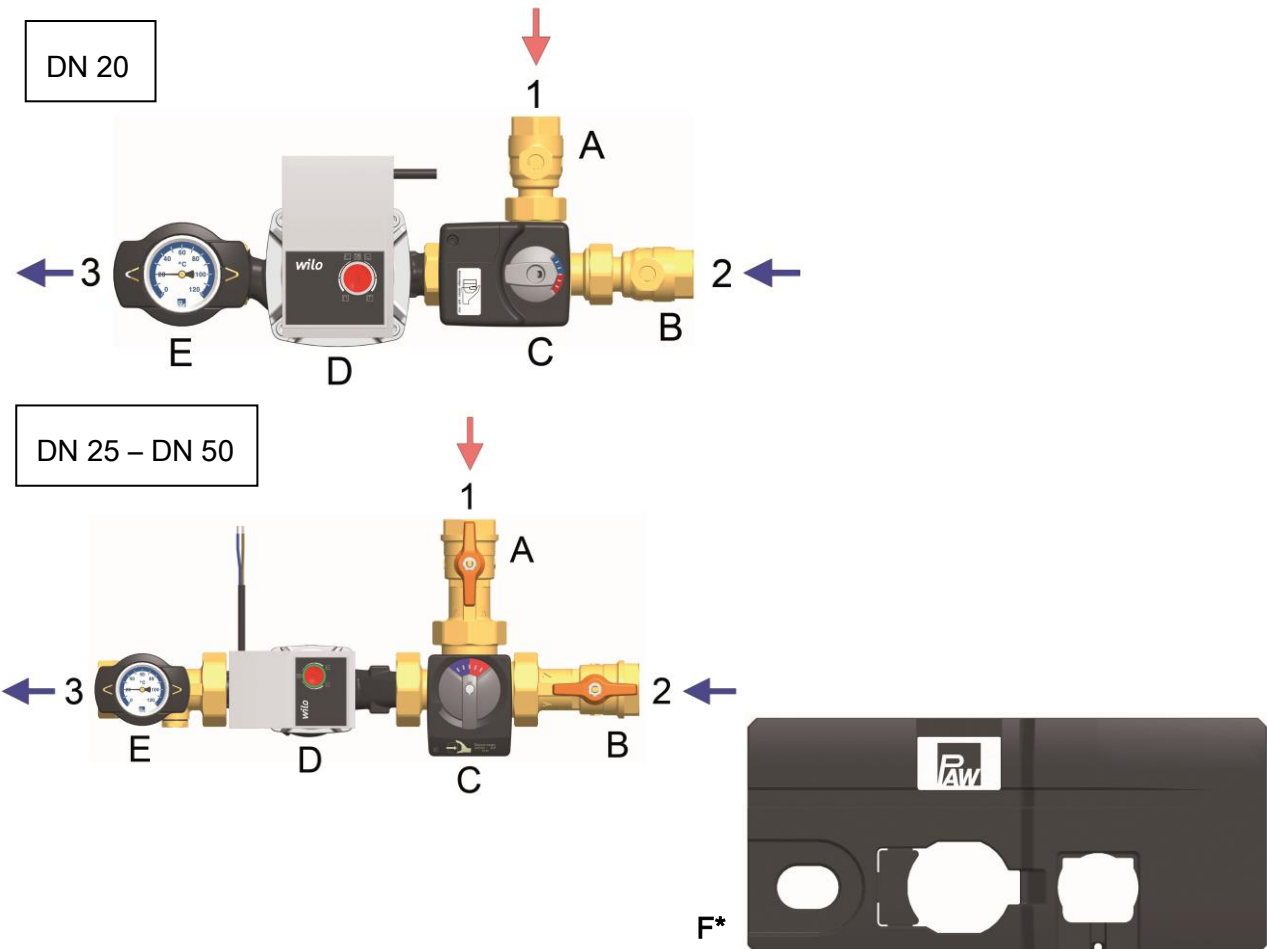

1 Bypass (from the boiler flow)

2 Return from the buffer tank

3 Return to the boiler

A Ball valve, flow

B Ball valve, return

C 3-way valve with actuator, DN 25 + DN 32 = 5 Nm, DN 40 + DN 50 = 10 Nm

D Heating pump

E Ball valve, return

F* Pump sets DN 25 and DN 32, with optional insulation (depends on the pump version)

3.2 Function

Pump sets for return flow temperature maintenance with actuator

The pump set prevents the temperature in the boiler from falling under the dew point, thus reducing contamination of the boiler.

The pump set is installed between the buffer tank and the boiler. The actuator is controlled by an external controller. The actuator opens the 3-way valve as soon as the boiler circuit has reached the set opening temperature. Then the pump can charge the tank.

Application ranges:

- for heat sources requiring a return flow temperature maintenance, as for example solid fuel boilers, wood firing and stove heating systems

4 Assembly and installation [specialist]

NOTICE

Damage to property

The location of installation must be dry, load-carrying, frost-proof and protected against ultraviolet radiation to prevent material damage to the installation. Mount the pump in the return line to the boiler, as the high flow temperatures could damage the pump.

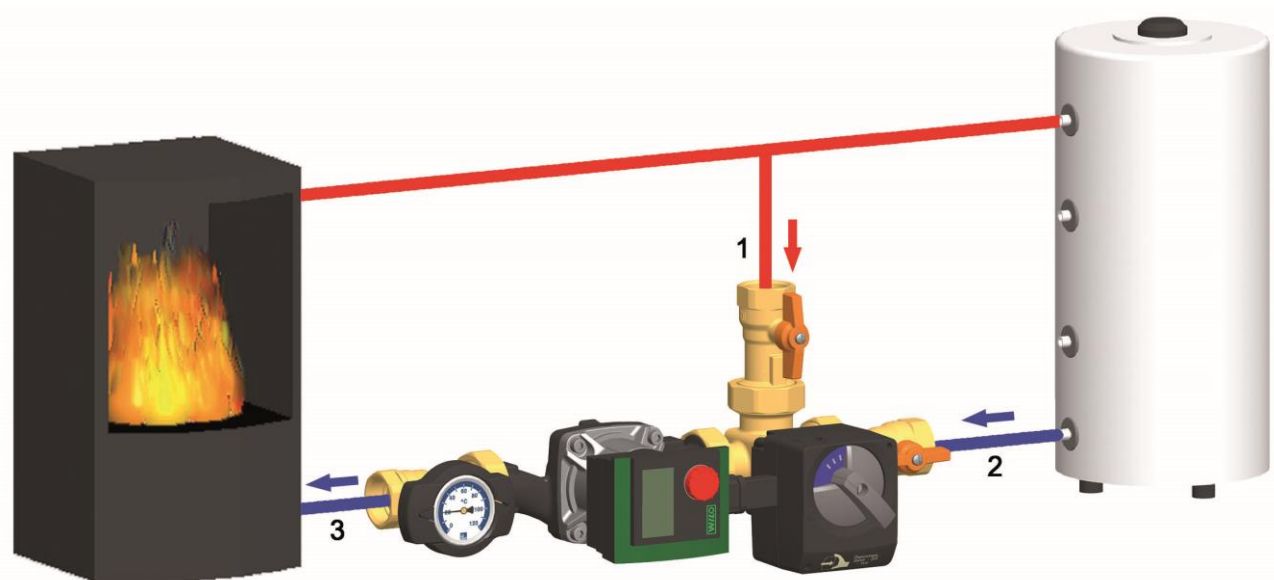

4.1 Assembly of the actuator [specialist]

4.1.1 Actuator SR2 - DN 20 / SR5 – DN 25 + DN 32 / SR10 - DN 40 + DN 50

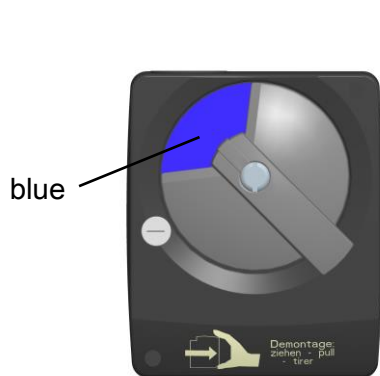

1. Set the actuator to manual mode by turning the selector switch. Only in the manual mode, the lever of the actuator can be manually adjusted.

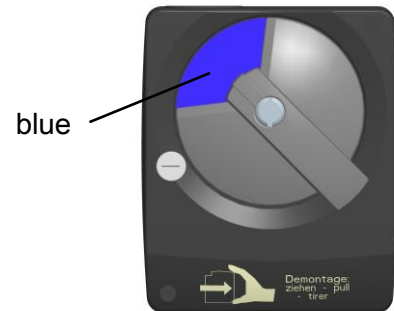

2. Turn the adjusting lever to the left into the position „blue“.

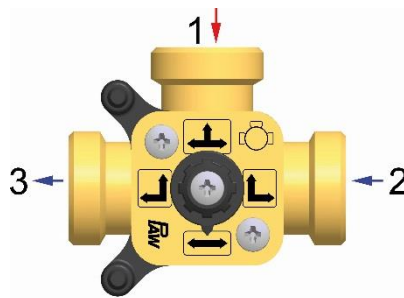

3. Turn the rotary knob of the 3-way valve such that the nose points downwards or to the left to \leftrightarrow .

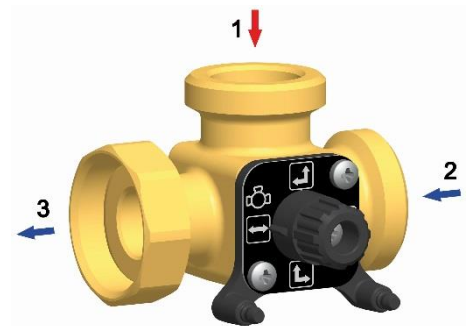



4. Turn the actuator as shown on the figure and mount it to the 3-way valve.
 5. Connect the actuator to the controller.
 6. Set the automatic mode on the actuator.
- The actuator is ready for operation.





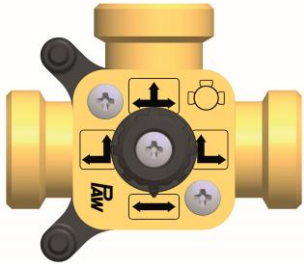
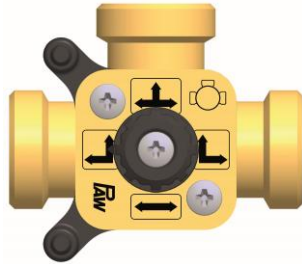
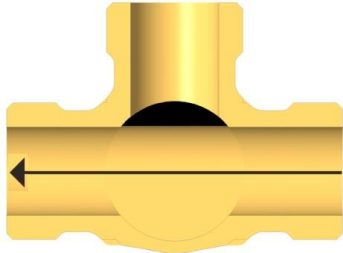
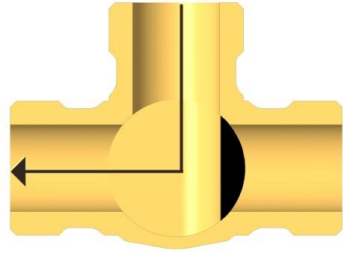

When the actuator is activated, it turns 90° in clockwise direction!

When the actuator is activated, it turns 90° in clockwise direction!

Actuator SR2 - DN 20

100% of return	100% from the boiler flow
 <p>Position "blue"</p>	 <p>Position "red"</p>
 <p>Nose points to ↔</p>	 <p>Nose points to ↗</p>
	

Actuator SR5 – DN 25 + DN 32 / SR10 - DN 40 + DN 50

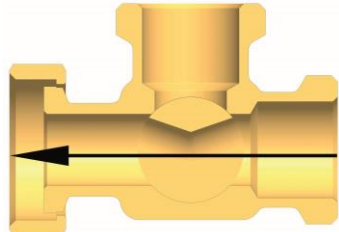
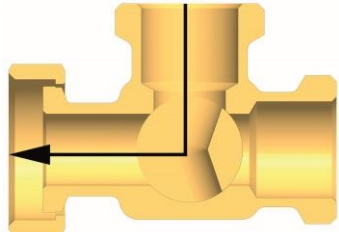
100% of return	100% from the boiler flow
 <p>Position "blue"</p>	 <p>Position "red"</p>
 <p>Nose points to ↔</p>	 <p>Nose points to ↗</p>
	

5 Technical data DN 20 - DN 50

Pump sets	DN 20	DN 25	DN 32	DN 40	DN 50
Dimensions					
Installation height	134 mm	187 mm	217 mm	266 mm	296 mm
Installation length	359 mm	505 mm	498 mm	736 mm	792 mm
Connections	¾" int.thr.	1" int.thr.	1¼" int.thr.	1½" int.thr.	2" int. thr.
Hydraulics					
Max. pressure	6 bars	6 bars	6 bars	6 bars	6 bars
Max. temperature	110 °C	110 °C	110 °C	110 °C	110 °C
K _{vs} value [m ³ /h]	5.45	10	16	42	57
Materials					
Valves and fittings	Brass				
Gaskets	EPDM / NBR				

Scope of delivery, pressure drop and pump characteristics: see last pages of these instructions.

Table des matières

1 Informations générales	20
1.1 Champ d'application de la présente notice	20
1.2 Utilisation conforme à l'emploi prévu	20
2 Consignes de sécurité	21
3 Description du produit.....	22
3.1 Équipement.....	22
3.2 Fonction	23
4 Montage et installation [Expert]	23
4.1 Montage du servomoteur [Expert]	24
4.1.1 Servomoteur SR2 - DN 20 / SR5 – DN 25 + DN 32 / SR10 - DN 40 + DN 50	24
5 Données techniques DN 20 - DN 50.....	26

1 Informations générales



Lisez attentivement toutes les instructions de la présente notice avant de procéder à l'installation et à la mise en service. Gardez cette notice à proximité de l'installation pour vous y référer ultérieurement.

1.1 Champ d'application de la présente notice

Cette notice décrit l'installation, la mise en service, le fonctionnement et l'utilisation des kits de pompe DN 20 - DN 50 pour le maintien de la température de retour avec servomoteur. Quant aux autres composants de l'installation, comme la pompe, le régulateur et le servomoteur, veuillez vous reporter aux notices d'utilisation des fabricants respectifs. Les chapitres avec la désignation [Expert] sont destinés exclusivement au personnel qualifié.

1.2 Utilisation conforme à l'emploi prévu

Le kit de pompe doit uniquement être utilisé dans les circuits de chauffage en respectant les limites techniques indiquées dans la présente notice.

Il est **interdit** d'utiliser le kit de pompe dans les circuits pour eau potable.

Toute utilisation contraire aux instructions mène à l'exclusion de tous les droits de garantie.

Le produit correspond aux directives pertinentes en vigueur et est homologué CE.

La déclaration de conformité est disponible sur demande auprès du fabricant.

N'utilisez que des accessoires PAW avec le kit de pompe.



Les matériaux d'emballage sont composés de matières recyclables.

2 Consignes de sécurité

L'installation et la mise en service ainsi que le raccordement des composants électriques exigent des connaissances spéciales qui correspondent à une formation professionnelle reconnue de mécanicien spécialisé dans le domaine de la technique sanitaire, du chauffage et de la climatisation ou à une qualification comparable [Expert].

Lors de l'installation et de la mise en service, il est impératif de respecter :

- les règles nationales et régionales s'appliquant au secteur
- les directives sur la prévention des accidents de travail
- les instructions et consignes de sécurité de ce document

 ATTENTION	
	<p>Dommages corporels et matériels !</p> <p>Le kit de pompe doit uniquement être utilisé dans les circuits de chauffage remplis par de l'eau de chauffage conforme aux normes VDI 2035 / Ö-Norm H 5195-1.</p> <p>Il est interdit d'utiliser le kit de pompe dans les circuits pour eau potable.</p>

AVIS

Dégâts matériels dus à des huiles minérales !

Les produits contenant de l'huile minérale endommagent considérablement les éléments d'étanchéité en EPDM qui peuvent ainsi perdre leurs propriétés d'étanchéité. Nous déclinons toute responsabilité concernant les dommages résultant de joints d'étanchéité endommagés de cette manière et nous ne garantissons pas de remplacement gratuit.

- Évitez impérativement que les éléments d'étanchéité en EPDM entrent en contact avec des substances contenant de l'huile minérale.
- Utilisez un lubrifiant sans huiles minérales à base de silicone ou de polyalkylène, comme par exemple Unisilikon L250L ou Syntheso Glep 1 de l'entreprise Klüber ou un spray de silicone.

3 Description du produit

Les kits de pompe sont des groupes de robinetteries prémontés pour les circuits de chauffage. La pompe intégrée peut être isolée par les vannes à sphère, ce qui permet un remplacement de la pompe sans vidange.

3.1 Équipement

DN 20

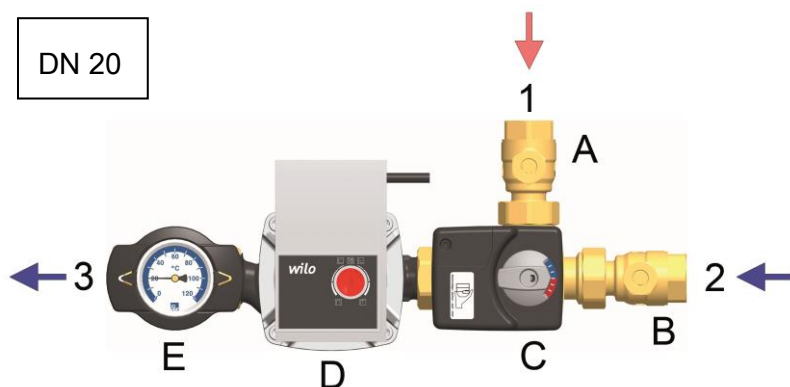

DN 25 – DN 50

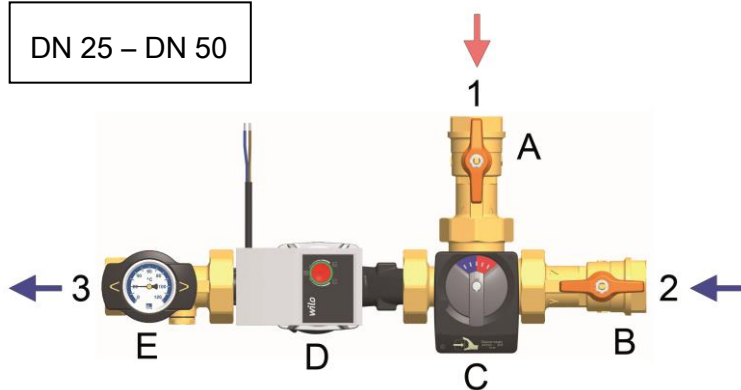

- | | |
|----|--|
| 1 | Bypass (du départ chaudière) |
| 2 | Retour du ballon tampon |
| 3 | Retour vers la chaudière |
| A | Vanne à sphère, départ |
| B | Vanne à sphère, retour |
| C | Vanne à 3 voies avec servomoteur, DN 25 + DN 32 = 5 Nm, DN 40 + DN 50 = 10 Nm |
| D | Pompe de chauffage |
| E | Vanne à sphère, retour |
| F* | Kits de pompe DN 25 et DN 32, avec isolation optionnelle (en fonction de la pompe) |

3.2 Fonction

Kits de pompe pour le maintien de la température de retour avec servomoteur

Le kit de pompe empêche la température de la chaudière de tomber en dessous du point de rosée et réduit ainsi l'encrassement de la chaudière.

Le kit de pompe est monté entre le ballon tampon et la chaudière. Le servomoteur est actionné par un régulateur externe. Le servomoteur n'ouvre la vanne à 3 voies qu'au moment où le circuit chaudière a atteint la température d'ouverture réglée. La pompe peut désormais charger le ballon.

Champ d'application :

- pour les sources de chaleur nécessitant le maintien de la température de retour, comme par exemple les chaudières à combustibles solides, les cheminées et les poêles à bois

4 Montage et installation [Expert]

AVIS

Dommages matériels

Afin d'éviter l'endommagement de l'installation, le lieu de montage doit être sec, stable, résistant au gel et protégé contre le rayonnement UV. Montez la pompe toujours dans le retour vers la chaudière afin d'éviter l'endommagement de la pompe par les températures de départ élevées.

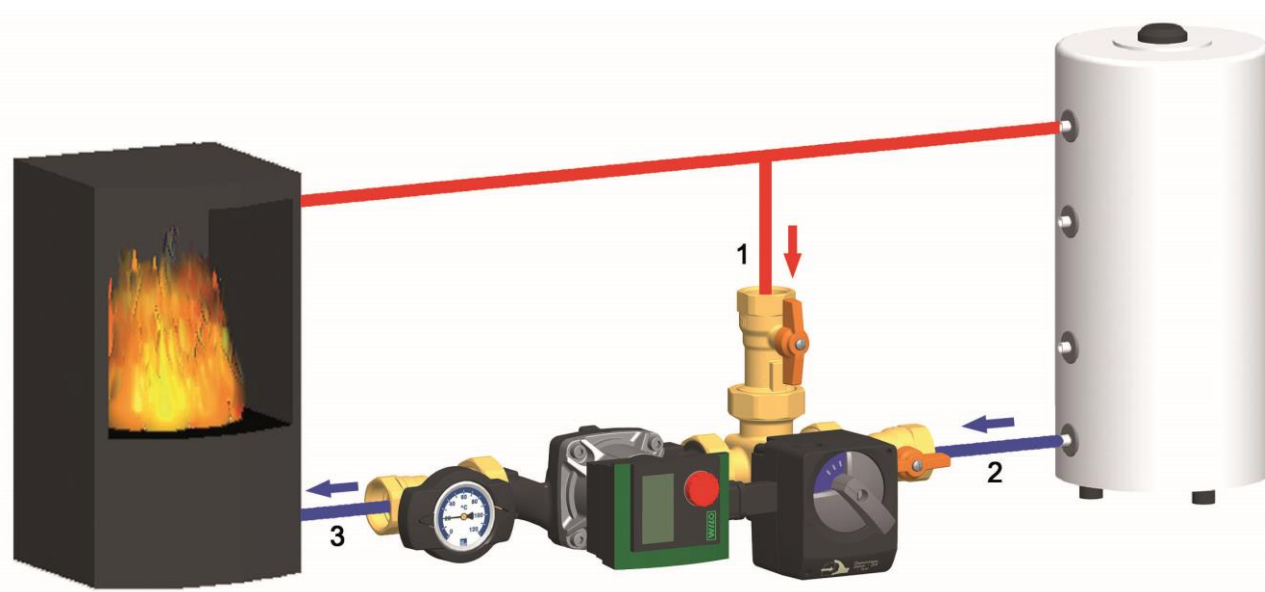

4.1 Montage du servomoteur [Expert]

4.1.1 Servomoteur SR2 - DN 20 / SR5 – DN 25 + DN 32 / SR10 - DN 40 + DN 50

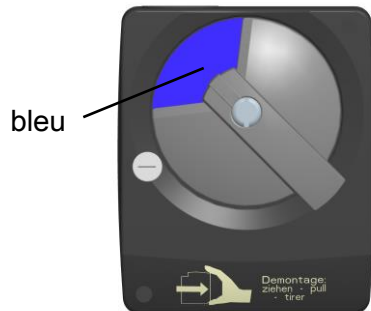

1. Mettez le servomoteur en mode manuel en tournant le sélecteur. En mode manuel, vous pouvez tourner la poignée de réglage du servomoteur manuellement.

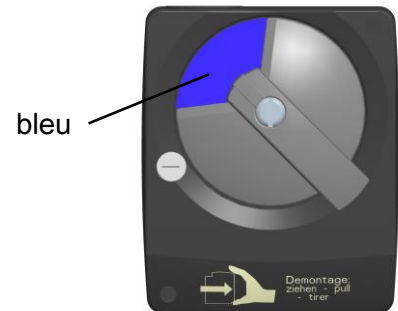

2. Tournez la poignée de réglage vers la gauche sur la position „bleu“.

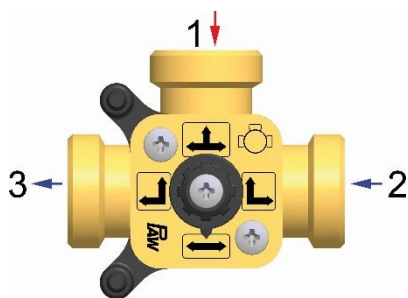

3. Tournez le bouton rotatif de la vanne à 3 voies de manière à ce que le nez montre vers le bas ou vers la gauche sur \longleftrightarrow .

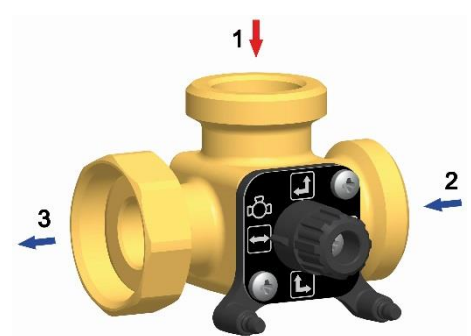

4. Tournez l'actionneur comme indiqué sur l'illustration et montez-le par encliquetage sur la vanne à 3 voies.



Lors de l'activation du servomoteur, le bouton tourne de 90° dans le sens des aiguilles d'une montre.

5. Raccordez le servomoteur au régulateur.
6. Mettez le servomoteur en mode automatique. Le servomoteur est maintenant opérationnel.

Lors de l'activation du servomoteur, le bouton tourne de 90° dans le sens des aiguilles d'une montre.

4 Montage et installation [Expert]

Servomoteur SR2 - DN 20

100 % de retour



Position "bleu"

100 % du départ chaudière



Position "rouge"



Nez montre sur ↔

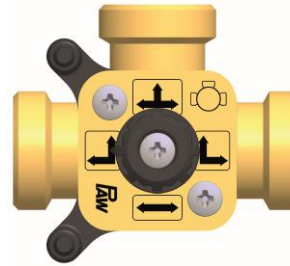

Nez montre sur ↗

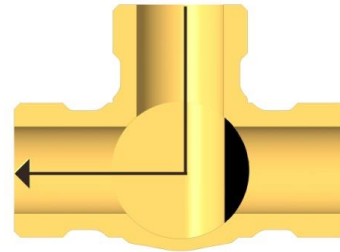
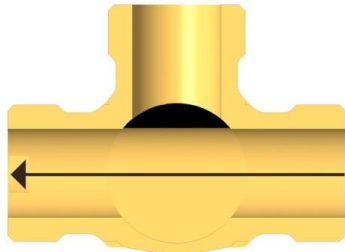

Servomoteur SR5 – DN 25 + DN 32 / SR10 - DN 40 + DN 50

100 % de retour



Position "bleu"

100 % du départ chaudière



Position "rouge"



Nez montre sur ↔



Nez montre sur ↗

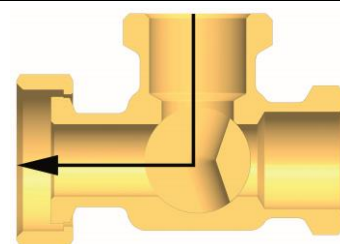
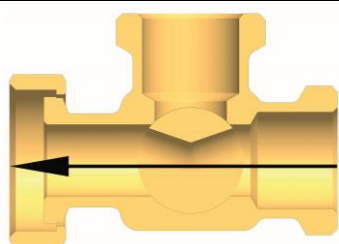

5 Données techniques DN 20 - DN 50

Kits de pompe	DN 20	DN 25	DN 32	DN 40	DN 50
Dimensions					
Hauteur d'installation	134 mm	187 mm	217 mm	266 mm	296 mm
Longueur d'installation	359 mm	437 mm	497 mm	735 mm	792 mm
Raccords	Fil. int. ¾"	Fil. int. 1"	Fil. int. 1¼"	Fil. int. 1½"	Fil. int. 2"
Hydraulique					
Pression maximale	6 bars	6 bars	6 bars	6 bars	6 bars
Température maximale	110 °C	110 °C	110 °C	110 °C	110 °C
Valeur K_{vs} [m³/h]	5,45	10	16	23	25
Matériaux					
Robinetteries	Laiton				
Joints	EPDM / NBR				

Pour le volume de livraison et les courbes caractéristiques de perte de charge et des pompes, voir les dernières pages de cette notice.

Índice

1	Información general	28
1.1	Campo de aplicación del manual.....	28
1.2	Uso conforme a lo previsto.....	28
2	Indicaciones de seguridad	29
3	Descripción del producto	30
3.1	Equipamiento	30
3.2	Función	31
4	Montaje e instalación [técnico]	31
4.1	Montaje e instalación del accionador [técnico].....	32
4.1.1	Accionador SR2 - DN 20 / SR5 – DN 25 + DN 32 / SR10 - DN 40 + DN 50.....	32
5	Datos técnicos DN 20 – DN 50	34

1 Información general



Lea cuidadosamente este manual antes de la instalación y puesta en servicio.
Guarde este manual cerca de la instalación.

1.1 Campo de aplicación del manual

Este manual describe la función, instalación, puesta en servicio y el manejo del kit de bomba DN 20 - DN 50 para el mantenimiento de la temperatura de retorno con accionador. Para otros componentes de la instalación como por ejemplo la bomba, el regulador o el accionador, por favor tenga en cuenta las instrucciones de los respectivos fabricantes. Los capítulos identificados con [técnico] están dirigidos exclusivamente a instaladores especializados.

1.2 Uso conforme a lo previsto

El kit de bomba debe emplearse únicamente en instalaciones de calefacción considerando los valores límites de orden técnico indicados en este manual.

El kit de bomba **no** debe emplearse en aplicaciones de agua caliente sanitaria.

Un empleo no conforme a lo previsto del kit de bomba lleva a la exclusión de cualquier derecho a hacer efectiva una responsabilidad en contra del fabricante o proveedor.

Este producto cumple con las directivas pertinentes y por lo tanto está etiquetado con la marca CE. La declaración de Conformidad está disponible bajo pedido.

Emplee únicamente accesorios de PAW junto con el kit de bomba.

Los elementos de embalaje se componen de materiales reciclables que pueden reincorporarse al ciclo normal de materiales industriales.

2 Indicaciones de seguridad

La instalación y el funcionamiento, así como la conexión de los componentes eléctricos requieren conocimientos técnicos correspondientes a la profesión de mecánico de instalaciones sanitarias, de calefacción y aire acondicionado u otra profesión con similar nivel de conocimientos técnicos [técnico especializado].

Durante la instalación y la puesta en servicio debe prestarse atención a lo siguiente:

- normativa local, regional y estatal correspondiente
- normativa sobre prevención de accidentes de la asociación profesional
- instrucciones e indicaciones de seguridad del presente manual

	<p>! PRECAUCIÓN</p>
<p>¡Lesiones corporales y daños materiales!</p> <p>El kit de bomba es apto únicamente para aplicaciones en sistemas de calefacción con agua de calefacción según VDI 2035 / Ö-Norm H 5195-1.</p> <p>El kit de bomba no debe emplearse en aplicaciones de agua caliente sanitaria.</p>	

ATENCIÓN

¡Daños en materiales debido a aceites minerales!

Los productos que contienen aceites minerales dañan los elementos obturadores de EPDM en forma duradera, con lo cual éstos pierden sus propiedades obturadoras. No asumimos responsabilidad ni prestación de garantía alguna por daños resultantes de juntas dañadas de tal forma.

- Evite estrictamente que EPDM entre en contacto con sustancias que contengan aceites minerales.
- Emplee un lubricante sin aceites minerales y en base de silicona o polialquileno, como por ejemplo Unisilikon L250L y Syntheso Glep 1 de Klüber, o un aerosol de silicona.

3 Descripción del producto

Los kits de bomba son grupos de instrumentos premontados para instalaciones de calefacción. La bomba puede bloquearse por medio de las llaves esféricas así facilitando trabajos de mantenimiento, sin tener que vaciar el agua del circuito de calefacción.

3.1 Equipamiento

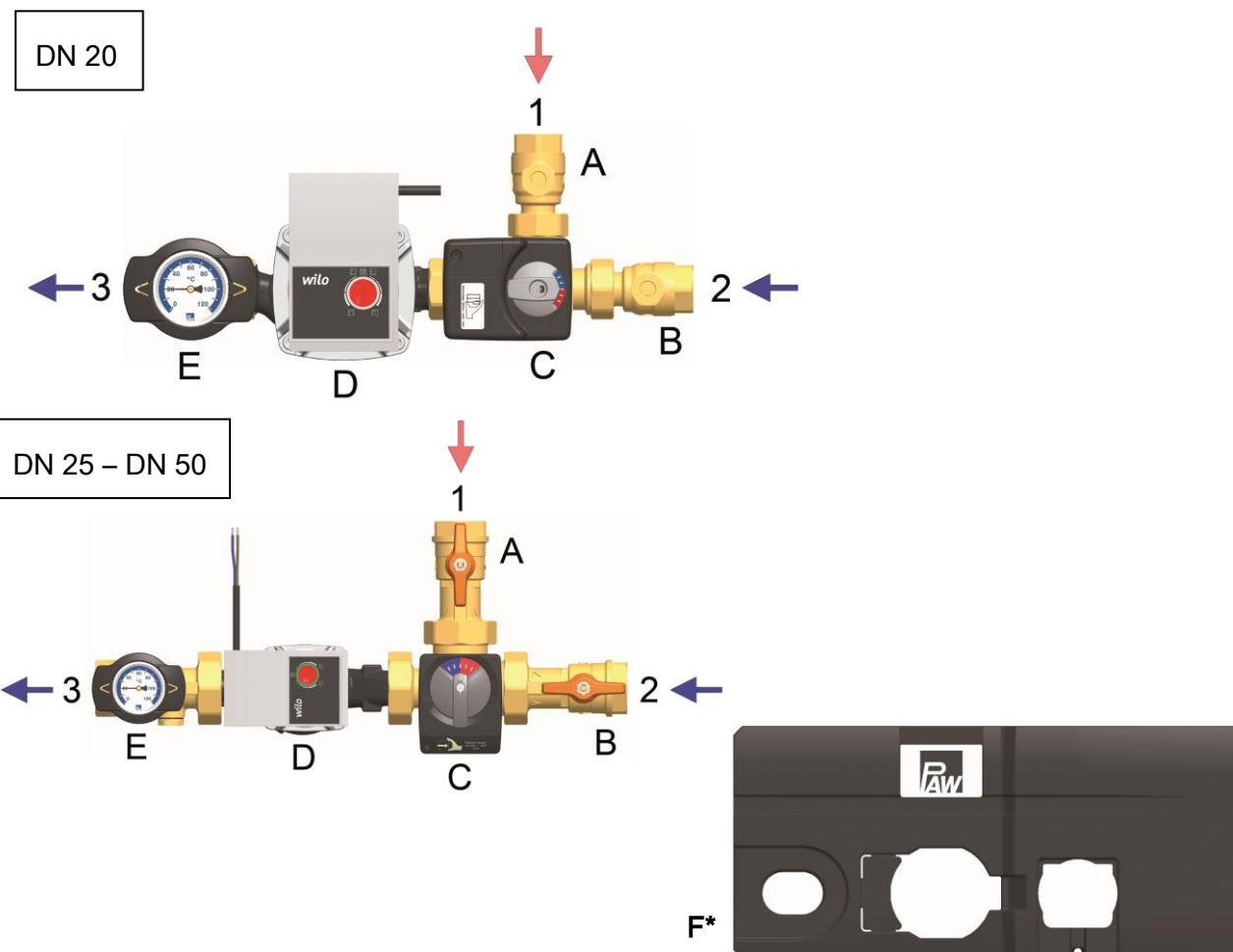

1 Bypass (desde la alimentación de caldera)

2 Retorno desde el acumulador intermedio

3 Retorno hacia la caldera

A Alimentación llave esférica

B Retorno llave esférica

C Válvula de 3 vías con accionador, DN 25 + DN 32 = 5 Nm, DN 40 + DN 50 = 10 Nm

D Bomba de calefacción

E Retorno llave esférica

F* Kits de bomba DN 25 y DN 32, con aislamiento opcional (depende de la versión de la bomba)

3.2 Función

Kits de bomba para mantenimiento de temperatura de retorno con accionador

Por medio del kit de bomba se impide que la temperatura descienda al punto de rocío en la caldera y por eso no se contamina la caldera.

El kit de bomba se instala entre el acumulador intermedio y la caldera. El accionador es activado por un regulador externo. El accionador abre la válvula de 3 vías en cuanto el circuito de la caldera alcance la temperatura de apertura ajustada. Después el rendimiento de la bomba está disponible para cargar el acumulador.

Campos de aplicación:

- para fuentes de calor que requieren un mantenimiento de la temperatura de retorno elevada, como p.ej. calderas de combustible sólido, instalaciones de calefacción a leña y chimeneas

4 Montaje e instalación [técnico]

ATENCIÓN

Daños materiales

Para impedir daños de la instalación, el lugar de montaje debe estar seco, tener suficiente capacidad de carga, estar protegido contra las heladas y contra la radiación UV. Siempre instale la bomba en el retorno de la caldera ya que ésta podría ser deteriorada debido a las temperaturas elevadas.

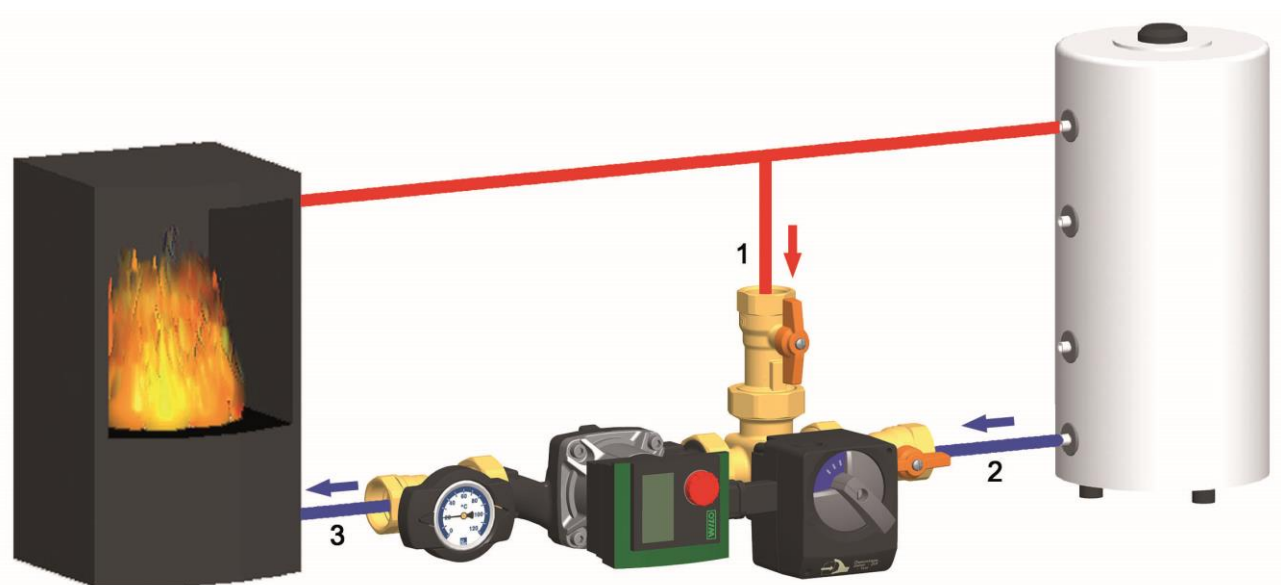

4.1 Montaje e instalación del accionador [técnico]

4.1.1 Accionador SR2 - DN 20 / SR5 – DN 25 + DN 32 / SR10 - DN 40 + DN 50



	<p>1. Ponga en el accionador el modo manual con la ayuda de un destornillador. Sólo si se ajusta el modo manual, puede ajustar el accionador a mano.</p>	
	<p>2. Gire el pomo hacia izquierda en posición „azul”.</p> <p>3. Gire el botón giratorio de la válvula de tres vías de modo que el lado aplanado indique hacia arriba o hacia izquierda a \longleftrightarrow.</p>	
	<p>4. Gire el accionador como representado y póngalo en la válvula de tres vías.</p> <p>5. Conecte el accionador al regulador.</p> <p>6. Ponga en el accionador el modo automático. Ahora, el accionador es listo para el servicio.</p>	

¡Si el accionador es activado, éste torce 90° en el sentido de las agujas del reloj!



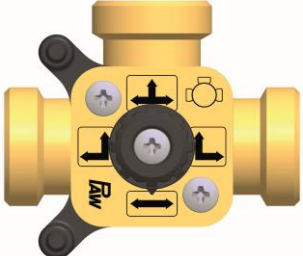
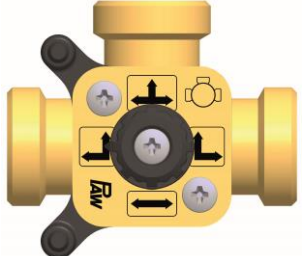
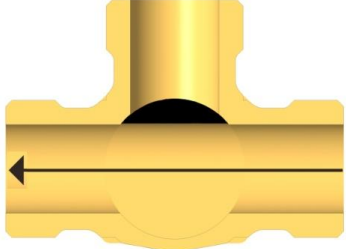
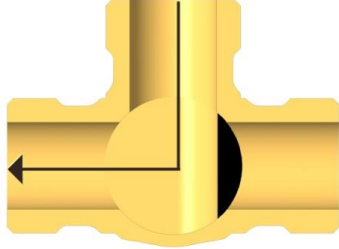

¡Si el accionador es activado, éste torce 90° en el sentido de las agujas del reloj!

4 Montaje e instalación [técnico]

Accionador SR2 - DN 20

100 % retorno	100% desde la alimentación de la caldera
 <p>Posición "azul"</p>	 <p>Posición "rojo"</p>
 <p>Nariz indica hacia ←→</p>	 <p>Nariz indica hacia ←↗</p>
	

Accionador SR5 – DN 25 + DN 32 / SR10 - DN 40 + DN 50

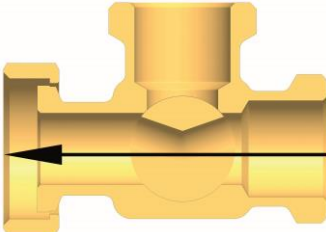
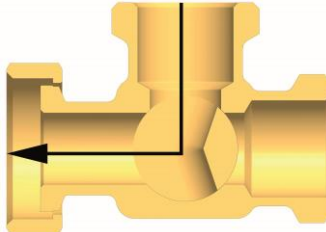
100 % retorno	100% desde la alimentación de la caldera
 <p>Posición "azul"</p>	 <p>Posición "rojo"</p>
 <p>Nariz indica hacia ←→</p>	 <p>Nariz indica hacia ←↗</p>
	

5 Datos técnicos DN 20 – DN 50

Kits de bomba	DN 20	DN 25	DN 32	DN 40	DN 50
Dimensiones					
Altura de montaje	134 mm	187 mm	217 mm	266 mm	296 mm
Longitud de montaje	359 mm	437 mm	497 mm	735 mm	792 mm
Conexiones	¾" rosca int.	1" rosca int.	1¼" rosca int.	1½" rosca int.	2" rosca int.
Hidráulica					
Presión máx.	6 bar	6 bar	6 bar	6 bar	6 bar
Temperatura máx.	110 °C	110 °C	110 °C	110 °C	110 °C
Caudal K _{vs} [m³/h]	5,45	10	16	23	25
Materiales					
Valvulería	Latón				
Juntas	EPDM / NBR				

Entrega y curvas características de la bomba y de pérdida de presión: véase las páginas últimas de este manual.

Indice

1	Informazioni generali	36
1.1	Campo di applicazione delle istruzioni.....	36
1.2	Uso conforme allo scopo.....	36
2	Avvertenze di sicurezza.....	37
3	Descrizione del prodotto	38
3.1	Dotazione.....	38
3.2	Funzione	39
4	Montaggio e installazione [esperto]	39
4.1	Montaggio del servomotore [esperto]	40
4.1.1	Servomotore SR2 - DN 20 / SR5 – DN 25 + DN 32 / SR10 - DN 40 + DN 50	40
5	Dati tecnici DN 20 – DN 50	42

1 Informazioni generali



Leggere attentamente le presenti istruzioni prima dell'installazione e della messa in funzione. Conservare le istruzioni presso l'impianto per una successiva consultazione.

1.1 Campo di applicazione delle istruzioni

Le presenti istruzioni descrivono il funzionamento, l'installazione, la messa in servizio e l'uso degli set di pompe DN 20 - DN 50 per l'innalzamento della temperatura di ritorno con servomotore. Per gli altri componenti dell'impianto, come ad es. la pompa, il regolatore o il servomotore, osservare le istruzioni dei rispettivi costruttori. I capitoli identificati dalla scritta [esperto] si rivolgono esclusivamente agli specialisti del settore.

1.2 Uso conforme allo scopo

Il set di pompa può essere utilizzato nei circuiti di riscaldamento solamente in considerazione dei valori tecnici limite indicati nelle presenti istruzioni.

Il set di pompa non può essere usato per applicazioni con acqua potabile.

L'uso non conforme allo scopo esclude qualsiasi tipo di garanzia.

Il prodotto è conforme alle direttive rilevanti ed è munito della marcatura CE. La dichiarazione di conformità può essere richiesta.

Collegare al set di pompa solamente accessori PAW.



I materiali d'imballo sono riciclabili e possono essere di nuovo impiegati nel normale ciclo di produzione di materie prime.

2 Avvertenze di sicurezza

L'installazione, la messa in funzione nonché l'allacciamento dei componenti elettrici presuppongono conoscenze specialistiche, corrispondenti a un diploma di qualifica professionale riconosciuto, come impiantista termotecnico per impianti sanitari, di riscaldamento e di condizionamento ovvero a una professione con pari livello di conoscenze [esperto].

Durante l'installazione e la messa in funzione deve essere osservato quanto segue:

- normative regionali e sovraregionali rilevanti
- norme antinfortunistiche dell'Istituto di assicurazione contro gli infortuni sul lavoro
- indicazioni e avvertenze per la sicurezza delle presenti istruzioni per l'uso

 ATTENZIONE	
	<p>Danni personali e materiali!</p> <p>Il set di pompa è solo adatto per l'impiego in circuiti di riscaldamento con acqua di riscaldamento in conformità con VDI 2035 / Ö-Norm H 5195-1.</p> <p>Il set di pompa non può essere usato per applicazioni con acqua potabile.</p>

AVVISO

Danni materiali da oli minerali!

I prodotti con olio minerale danneggiano gli elementi di guarnizione EPDM il che compromette le caratteristiche di tenuta. Non ci assumiamo alcuna responsabilità per danni causati da guarnizioni danneggiate in questo modo né provvediamo alla spedizione di merce a titolo di garanzia.

- Evitare assolutamente che gli elementi EPDM vengano a contatto con sostanze contenenti oli minerali.
- Utilizzare un lubrificante senza olio minerale a base di silicone o polialchilene, come ad es. Unisilikon L250L e Syntheso Glep 1 della ditta Klüber o spray al silicone.

3 Descrizione del prodotto

Il set di pompa è costituito da una raccorderia premontata per circuiti di riscaldamento.

La pompa può essere bloccata tramite le valvole a sfera e può essere mantenuta senza dover scaricare l'acqua dal circuito di riscaldamento.

3.1 Dotazione

DN 20

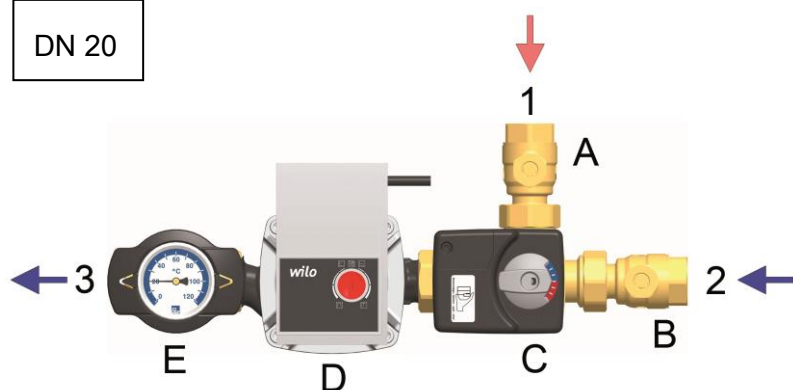

DN 25 – DN 50

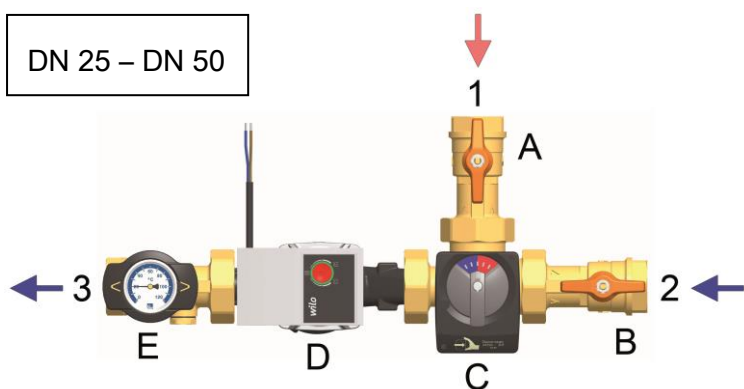

- 1 Bypass (dalla mandata caldaia)
- 2 Ritorno dall'accumulatore tampone
- 3 Ritorno alla caldaia

A Valvola a sfera, mandata

B Valvola a sfera, ritorno

C Valvola a 3 vie con servomotore, DN 25 + DN 32 = 5 Nm, DN 40 + DN 50 = 10 Nm

D Pompa riscaldamento

E Valvola a sfera, ritorno

F* Set pompe DN 25 e DN 32, con isolamento opzionale (dipende dalla versione della pompa)

3.2 Funzione

Set di pompa con servomotore per l'innalzamento della temperatura di ritorno

Grazie al set di pompa, si evita di scendere sotto il punto di condensazione nonché la formazione di catrame all'interno della caldaia.

Il set di pompa è montato tra il accumulatore tampone e il caldaia. Il servomotore viene comandato da un regolatore esterno. Il servomotore apre la valvola a 3 vie solo nel momento in cui il circuito della caldaia ha raggiunto la temperatura di apertura impostata. Poi la potenza della pompa è disponibile per caricare l'accumulatore.

Aree di impiego:

- per fonti di calore che richiedono un innalzamento temperatura di ritorno, come ad es. caldaie a combustibile solido, impianti a legna o caminetti e termocamini/stufe

4 Montaggio e installazione [esperto]

AVVISO

Danni materiali

Per il montaggio sicuro dell'impianto, il luogo di montaggio deve essere asciutto, staticamente stabile, nonché protetto da gelate e dalle radiazioni UV. Montare la pompa sempre sul ritorno della caldaia perché si potrebbe danneggiare a causa delle temperature di mandata elevate.

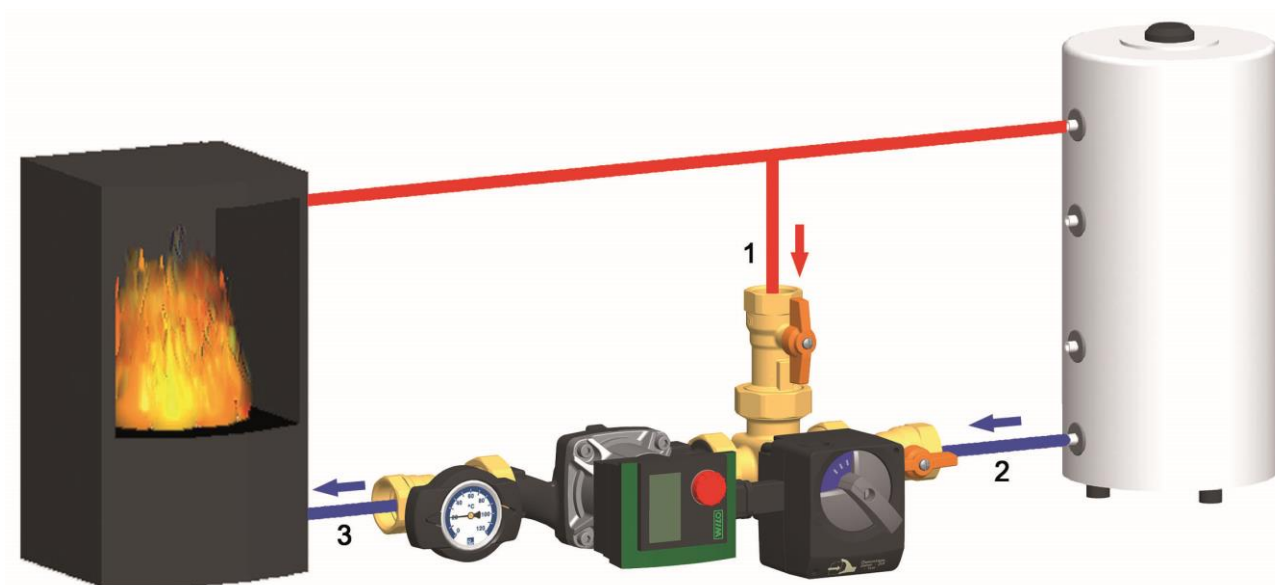

4.1 Montaggio del servomotore [esperto]

4.1.1 Servomotore SR2 - DN 20 / SR5 - DN 25 + DN 32 / SR10 - DN 40 + DN 50

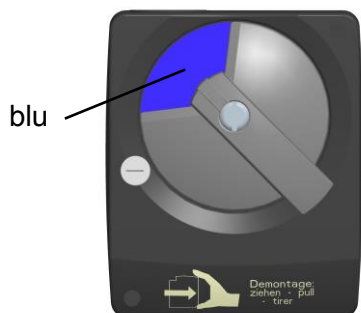

1. Utilizzare un giravite per regolare il funzionamento manuale nel servomotore. Solo in tale modalità è possibile azionare manualmente la manopola di regolazione del servomotore.

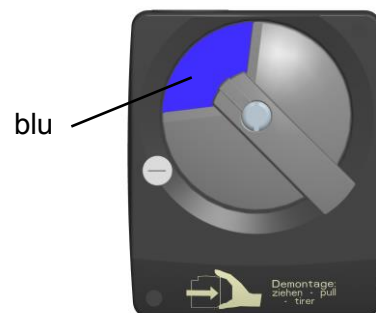

2. Ruotare la manopola di regolazione a sinistra in posizione "blu".

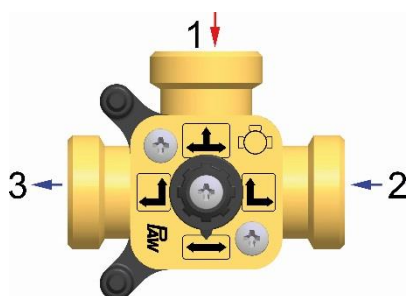

3. Ruotare la manopola della valvola a tre vie in modo che il nasello indichi verso il basso o verso sinistra in posizione \leftrightarrow .

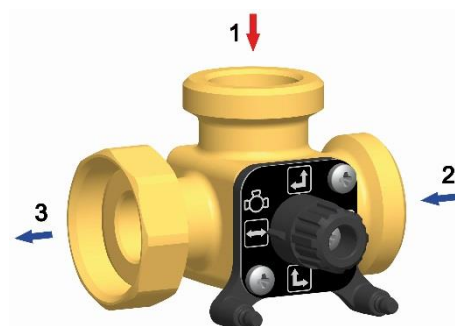

Se il motore è attivato, gira 90° in direzione orario!

4. Ruotare il servomotore come indicato e inserirlo sulla valvola a tre vie.
5. Collegare il servomotore al regolatore.
6. Regolare la modalità di funzionamento automatico sul servomotore. Il servomotore è ora pronto per il funzionamento.



Se il motore è attivato, gira 90° in direzione orario!

Stellmotor SR2 - DN 20

100 % di ritorno



Posizione "blu"

100 % di mandata caldaia



Posizione "rosso"

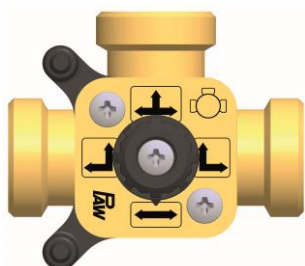

Nasello in posizione ↔

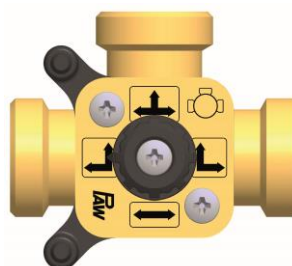

Nasello in posizione ↗

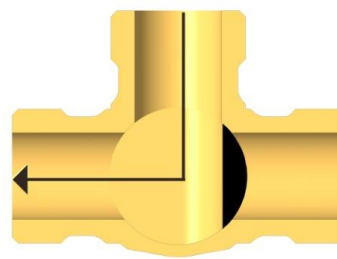
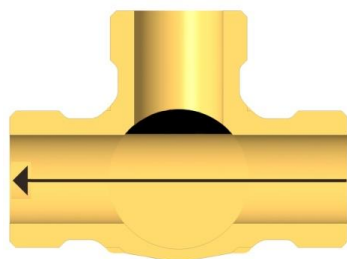

Stellmotor SR5 – DN 25 + DN 32 / SR10 - DN 40 + DN 50

100 % di ritorno



Posizione "blu"

100 % di mandata caldaia



Posizione "rosso"



Nasello in posizione ↔



Nasello in posizione ↗

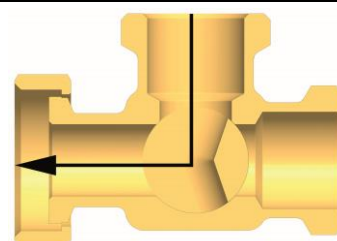
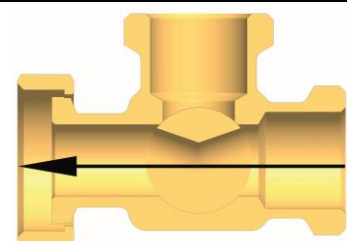

5 Dati tecnici DN 20 – DN 50

Set di pompa	DN 20	DN 25	DN 32	DN 40	DN 50
Dimensioni					
Altezza di montaggio	134 mm	187 mm	217 mm	266 mm	296 mm
Lunghezza	359 mm	437 mm	497 mm	735 mm	792 mm
Attacchi	¾" fil. fem.	1" fil. fem.	1¼" fil. fem.	1½" fil. fem.	2" fil. fem.
Idraulica					
Pressione max.	6 bar	6 bar	6 bar	6 bar	6 bar
Temperatura max.	110 °C	110 °C	110 °C	110 °C	110 °C
Valore K _{vs} [m ³ /h]	5,45	10	16	23	25
Materiali					
Raccorderia	Ottone				
Guarnizioni	EPDM / NBR				

Fornitura, perdita di pressione e curve caratteristiche delle pompe: Vedi l'ultime pagine di queste istruzioni.

Lieferumfang [Fachmann] / *Scope of delivery [Specialist]* /

Volume de livraison [Expert] / *Entrega [técnico]* / Dotazione [esperto]

HINWEIS / NOTICE / AVISO / AVIS / AVVISO

DE: Reklamationen und Ersatzteilanfragen/-bestellungen werden ausschließlich unter Angabe der Seriennummer bearbeitet! Die Seriennummer befindet sich auf dem Rücklaufrohr. /

EN: *Complaints and requests/orders of spare parts will only be processed with information on the serial number! The serial number is placed on the return pipe. /*

ES: ¡Reclamaciones y demandas/pedidos para piezas de recambio son tramitados únicamente con indicación del número de serie! El número de serie se encuentra en el tubo de retorno. /

FR : *Les réclamations et demandes/commandes de pièces de rechange ne sont traitées que si le numéro de série est indiqué ! Le numéro de série se trouve sur le tube de retour. /*

IT: Reclami e richieste/ordini di ricambi vengono elaborati esclusivamente se riportano l'indicazione del numero di serie! Il numero di serie si trova sul tubo di ritorno.

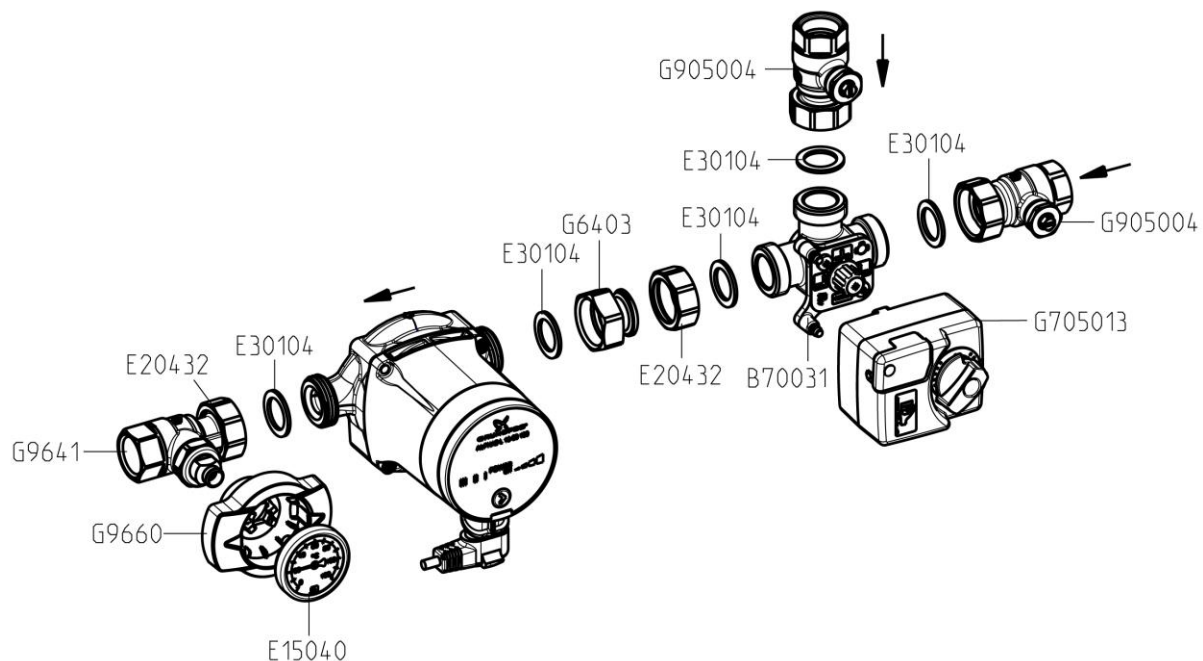

Artikelnr. Pumpenset / Item no. pump set / N° d'art. kit de pompe / N° de art. kit de bomba / Cod. art. set di pompe	Pumpe / Pump / Pompe / Bomba / Pompa	Art. Nr. / Item no. / N° d'art. / N° de art. / Cod. art.	EEI / IEE
96083WY6	Wilo-Yonos PARA RS 15/6-RKA	E1236036	< 0,20
96083WH6	Wilo-Stratos PICO 15/1-6	E1239615	< 0,20
96083GM6	Grundfos UPM3 Auto L 15-70 PP3	E1212360	< 0,20
96083GH6	Grundfos Alpha2.1 15-60	E121221	< 0,17

DN 25

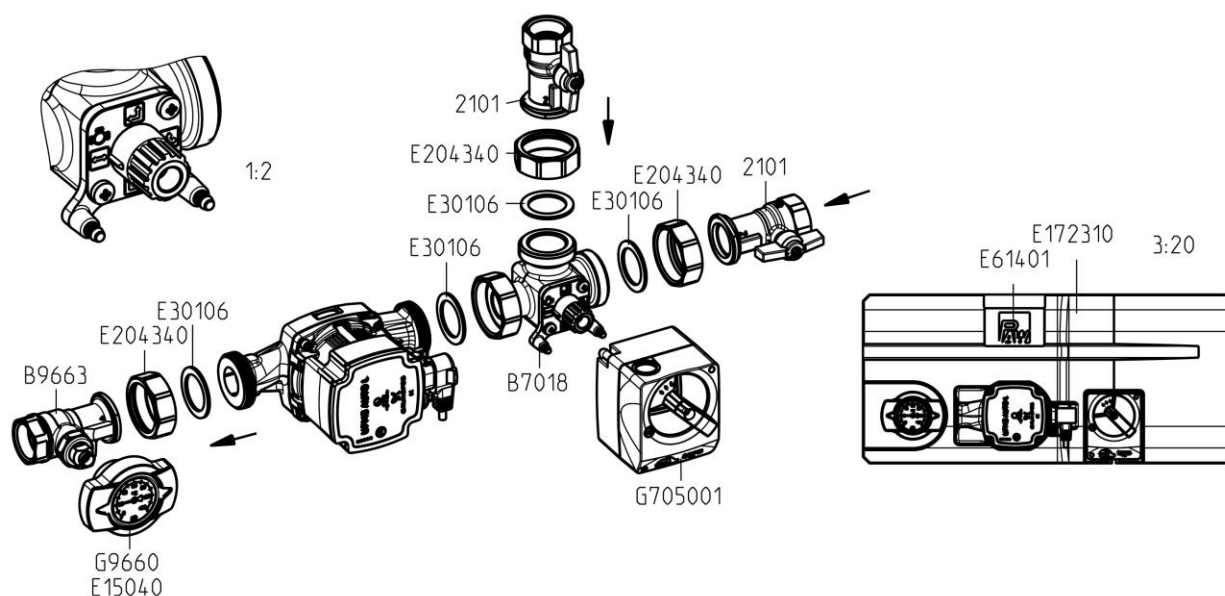

Artikelnr. Pumpenset / Item no. pump set / N° d'art. kit de pompe / N° de art. kit de bomba / Cod. art. set di pompe	Pumpe / Pump / Pompe / Bomba / Pompa	Art. Nr. / Item no. / N° d'art. / N° de art. / Cod. art.	EEI / IEE
960841WY6	Wilo-Yonos PARA RS 25/6-RKA	E1236046	< 0,20
960841WY8	Wilo-Yonos PARA RS 25/7.5-RKA	E1236048	< 0,21
960841WH6	Wilo-Stratos PICO 25/1-6	E1239625	< 0,20
960841GM6	Grundfos UPM3 Auto L 25-70 PP3	E1212460	< 0,20
960841GH6	Grundfos Alpha2.1 25-60	E121391	< 0,17
960841GL9	Grundfos UPML 25-95 Auto	E121394	< 0,23

DN 32

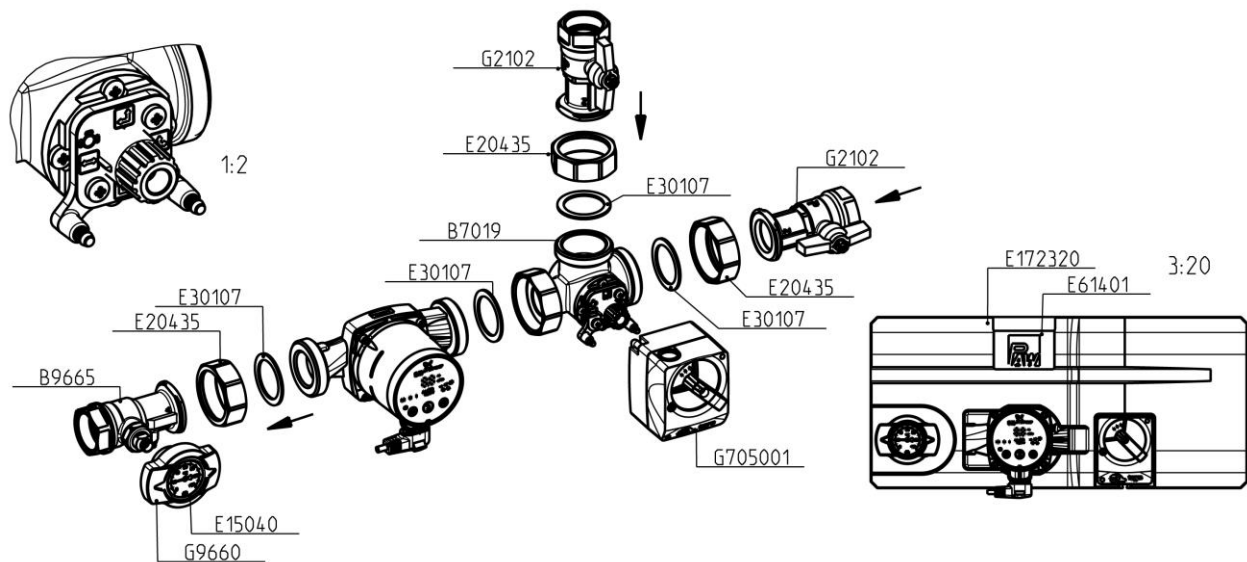

Artikelnr. Pumpenset / Item no. pump set / N° d'art. kit de pompe / N° de art. kit de bomba / Cod. art. set di pompe	Pumpe / Pump / Pompe / Bomba / Pompa	Art. Nr. / Item no. / N° d'art. / N° de art. / Cod. art.	EEI / IEE
960851WY6	Wilo-Yonos PARA RS 30/6-RKA	E1236056	< 0,20
960851WY10	Wilo-Yonos PARA HF 30/0.5-10	E12361510	< 0,20
960851GM6	Grundfos UPM3 Auto L 32-70 PP3	E1212560	< 0,20
960851GH6	Grundfos Alpha2.1 32-60	E121701	< 0,17

DN 40

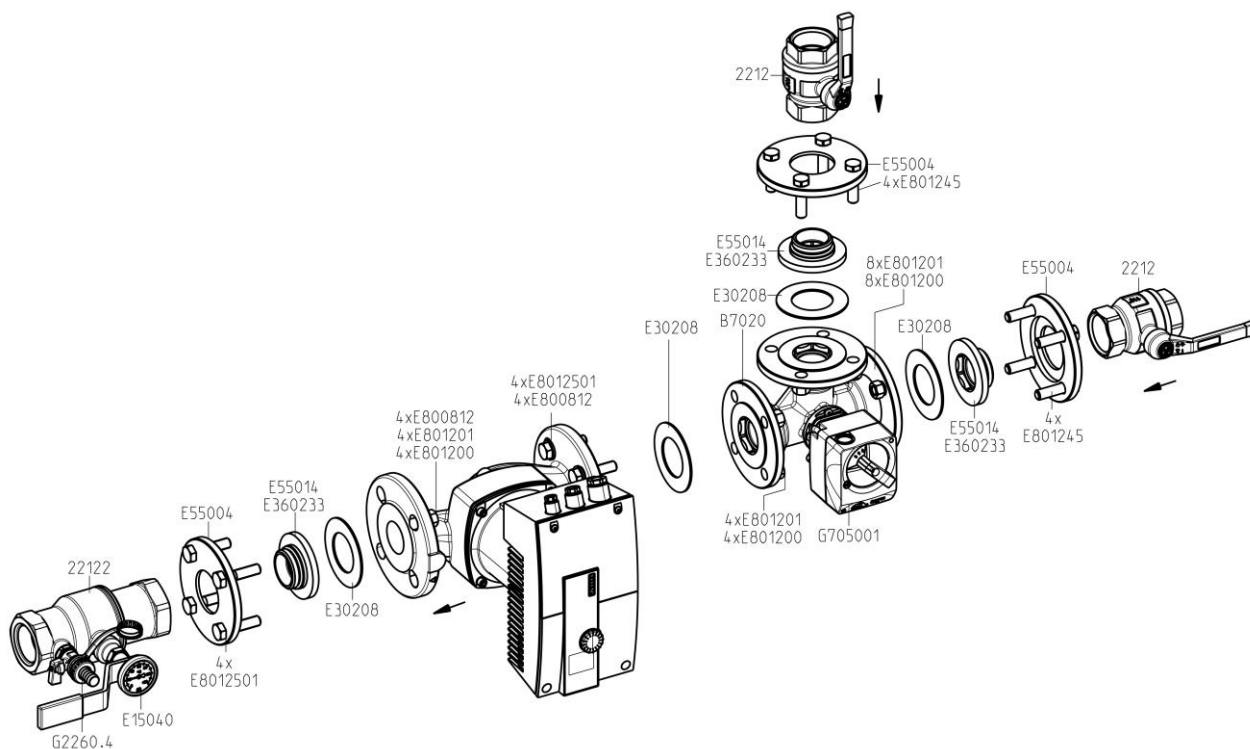

Artikelnr. Pumpenset / Item no. pump set / N° d'art. kit de pompe / N° de art. kit de bomba / Cod. art. set di pompe	Pumpe / Pump / Pompe / Bomba / Pompa	Art. Nr. / Item no. / N° d'art. / N° de art. / Cod. art.	EEI / IEE
960861WH12	Wilo-Stratos PARA 30/1-12	E12395132	< 0,23
960861WY12	Wilo-Yonos PARA HF 40/0.5-12	E12361612	< 0,20
960861GL10	Grundfos Magna1 32-100	E1217310	< 0,21
960861GL12	Grundfos Magna1 40-120 F	E121761	< 0,21

DN 50

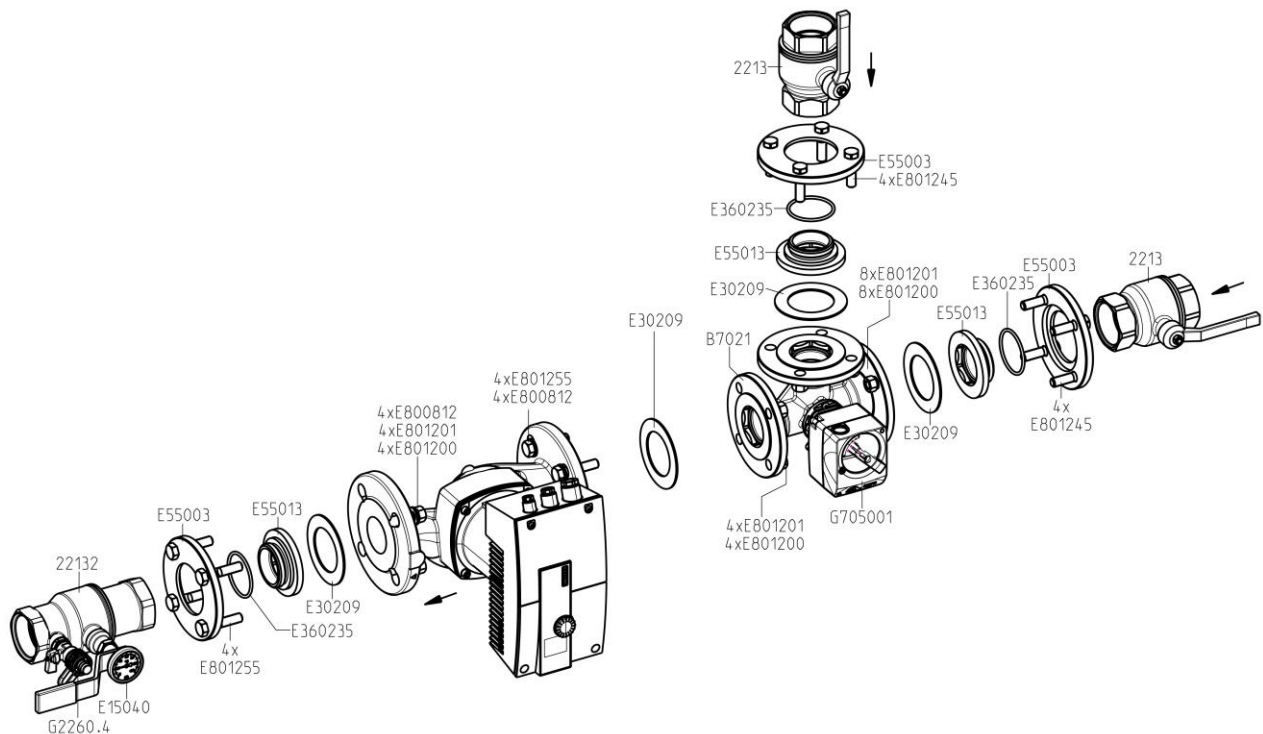

Artikelnr. Pumpenset / Item no. pump set / N° d'art. kit de pompe / N° de art. kit de bomba / Cod. art. set di pompe	Pumpe / Pump / Pompe / Bomba / Pompa	Art. Nr. / Item no. / N° d'art. / N° de art. / Cod. art.	EEI / IEE
960871WH12	Wilo-Stratos PARA 30/1-12	E12395132	< 0,23
960871WY9	Wilo-Yonos PARA HF 50/0.5-9	E1236189	< 0,20
960871GL10	Grundfos Magna1 32-100	E1217310	< 0,21
960871GL12	Grundfos Magna1 50-120 F	E121781	< 0,21

Reduzierflansche / Reducer flanges / Brides de réduction / Bidas reductoras / Flange di riduzione	Art. Nr. / Item no. / N° d'article / N° de art. / Cod. art.
DN 40	41610
DN 50	5162

Druckverlust- und Pumpenkennlinien / *Pressure drop and pump characteristics* /
 Perte de charge et caractéristiques des pompes / *Pérdida de presión y curvas*
características de la bomba / Perdita di pressione e curve caratteristiche delle pompe

DN 20

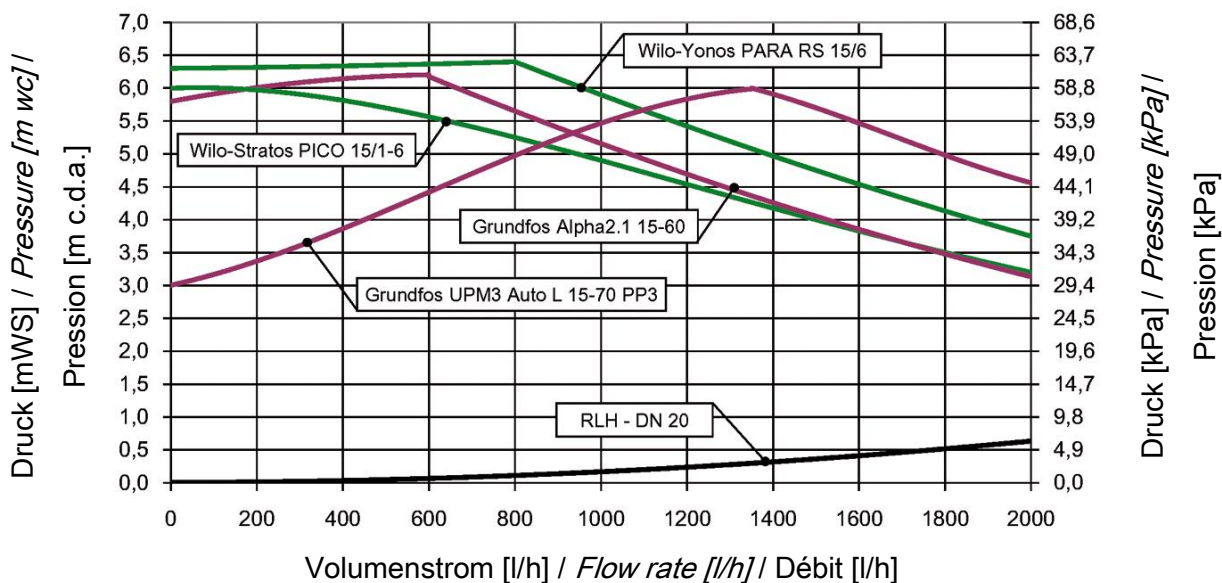

DN 25 + DN 32

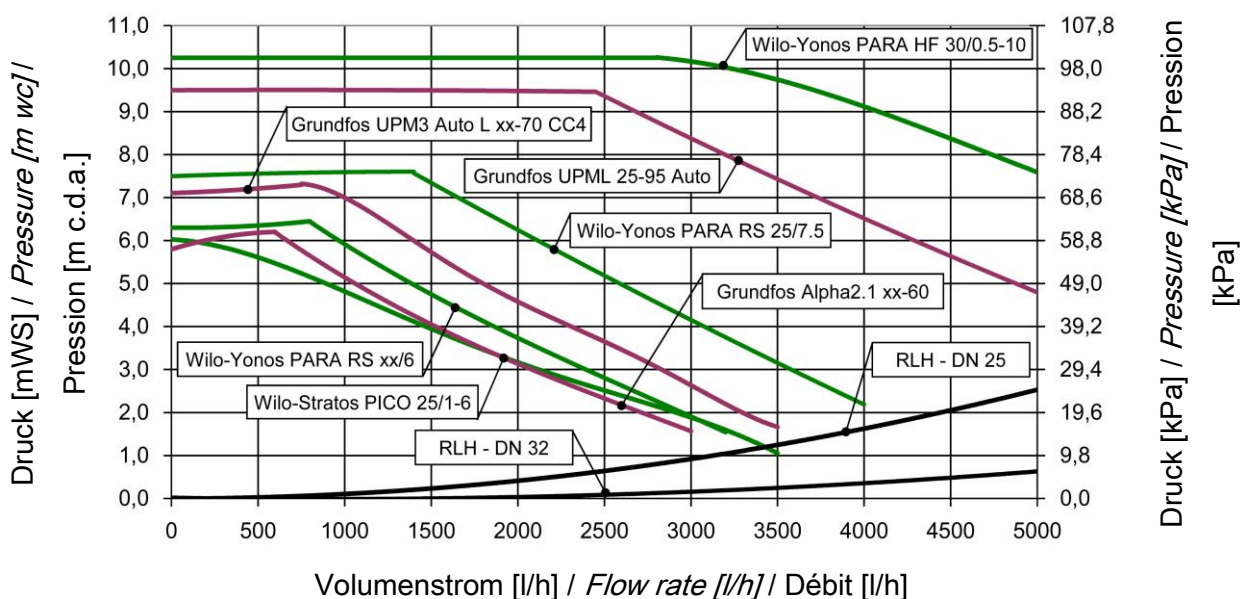

DN 40 + DN 50

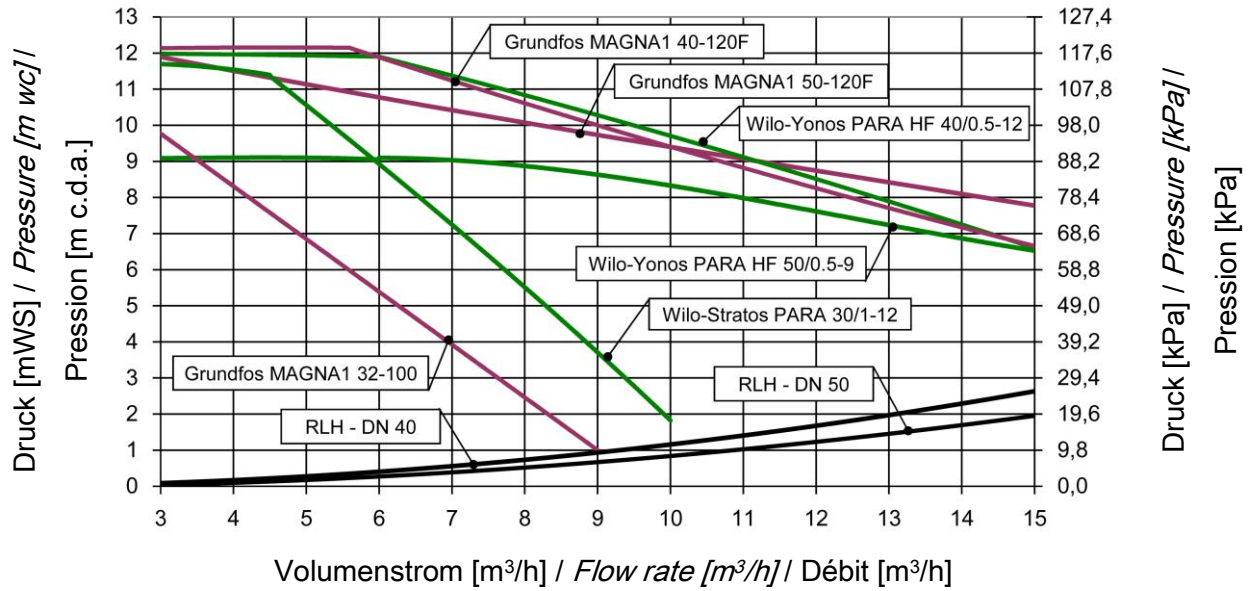



PAW GmbH & Co. KG
Böcklerstraße 11
D-31789 Hameln, Germany

www.paw.eu
Phone: +49 (0) 5151 9856 - 0
Fax: +49 (0) 5151 9856 - 98