



HEAT RECOVERY SINGLE ROOM UNIT WITH HEAT AND HUMIDITY RECOVERY

VENTO Expert A50-1 Pro
VENTO Expert A50-1 S Pro



EN

OPERATION MANUAL



BLAUBERG
Ventilatoren

CONTENTS

Introduction	3
General	3
Safety regulations	3
Transportation and storage regulations	3
Manufacturer's warranty	3
Unit design and functional principle	4
Modifications and options	6
Delivery set	6
Technical data	6
Mounting	7
Connection to power grid	12
Unit setup	13
Unit control	15
Technical maintenance	17
Troubleshooting	19
Acceptance certificate	20
Connection certificate	20
Warranty card	20

BLAUBERG Company is pleased to present our reversing single-room air handling unit with heat and humidity recovery **VENTO Expert A50-1 Pro / VENTO Expert A50-1 S Pro**.

INTRODUCTION

The present operation manual contains a technical description, technical data sheets, operation and mounting guidelines, safety precautions and warnings for safe and correct operation of the unit.

GENERAL

The single-room unit is designed for efficient energy saving supply and exhaust ventilation of flats, houses and other small premises.

The heat recovery technology is used to minimize ventilation heat losses.

The unit is equipped with a high-tech ceramic heat exchanger that provides the utilization of exhaust air heat energy for warming up the filtered supply air flow. The heat recovery efficiency of the heat exchanger is up to 97 %.

The unit is designed for indoor application with the ambient temperature ranging from -30 °C up to +50 °C and relative humidity up to 80 %.

The unit is designed for mounting through walls.

The unit is rated for continuous operation.

The unit is allowed for operation only after final mounting that includes installation of protecting devices in compliance with DIN EN ISO 13875 (DIN EN ISO 12100) as well as other construction safety equipment.

The unit design is constantly being improved, so some models can slightly differ from those ones described in this operation manual.

SAFETY REGULATIONS

The unit complies with the requirements according to the EU norms and directives, to the relevant EU-Low Voltage Equipment Directives, EU-Directives on Electromagnetic Compatibility.

All operations related to the unit electrical connections, servicing and repair operations are allowed only after disconnecting the unit from the power grid.

All mounting and servicing operations should be performed by duly qualified electricians with valid electrical work permit for works with electrical devices powered from AC up to 1000 V and after careful study of the present operation manual.

Please follow the safety regulations and working instructions (DIN EN 50 110, IEC 364).

Make sure the impeller and the casing are not damaged before connecting the unit to power supply. The casing internals must be free of any foreign objects which can damage the impeller blades or the motor.

The unit maintenance and repair are allowed only after power cut-off and full stop of the rotating parts.

Misuse of the unit or any unauthorized modification are not allowed.

The unit is designed for connection to AC single-phase power grid in compliance with the "Technical data" section.

The unit is rated for continuous operation under permanent power supply.

Measures should be taken to prevent smoke, carbon monoxide and other combustion products into the room through open flues or other fire-protection devices, as well as to eliminate the possibility of backflow of gas from devices that use gas or open flame.

The maximum permitted pressure difference per living units is 4 Pa.

The transported air must not contain any dust or other solid impurities as well as sticky substances or fibrous materials.

The unit is not rated for operation in a flammable or explosive medium.

Do not close or block the unit air inlet or outlet vent not to disturb the normal air passage.

Do not sit on the unit and do not put any objects on it.

When the unit generates unusual sounds, odour or emits smoke disconnect it from power supply and contact the distributor.

Fulfil the operation manual requirements to ensure a trouble-free and long service life of the unit.

Ingress Protection (IP) rating from solid objects and liquids IP 24.

TRANSPORTATION AND STORAGE REGULATIONS

Transportation of the unit is allowed by any vehicle provided the unit is transported in the original package and is protected against weather and mechanical damages.

Use hoist machinery for handling and transportation to prevent possible mechanical damages.

Fulfil the requirements for transportation of the specified cargo type during cargo-handling operations.

Store the unit in a dry and cool place in the original packing.

The storage environment must not be subjected to any aggressive and/or chemical evaporations, admixtures, foreign objects that may provoke corrosion and damage connection tightness.

Store the unit in an environment with minimized risk of mechanical damages, temperature and humidity fluctuations.

Do not expose the unit to the temperatures below +5 °C and above +40 °C.

Connection of the unit to power supply is allowed after the appliance has been kept indoors for minimum two hours.

MANUFACTURER'S WARRANTY

The unit complies with the requirements according to the EU norms and directives, to the relevant EU-Low Voltage Equipment Directives, EU-Directives on Electromagnetic Compatibility.

We hereby declare that the unit complies with the essential protection requirements of Electromagnetic Council Directive 2004/108/EC, 89/336/EEC and Low Voltage Directive 2006/95/EC, 73/23/EEC and CE-marking Directive 93/68/EEC on the approximation of the laws of the Member States relating to electromagnetic compatibility, which relate to electrical appliances used in set voltage classes.

The manufacturer hereby warrants normal operation of the unit over the period of two years from the retail sale date provided observance of the installation and operation regulations.

In case of a failure due to a manufacturing fault during the warranty period the consumer has the right to exchange it.

In the event that the purchase date stamp is not available warranty period is calculated from the manufacturing date.

The replacement is offered by the distributor.

The MANUFACTURER is not responsible for any damage resulting from any misuse of or gross mechanical interference with the unit.

Fulfil the operation manual requirements to ensure a trouble-free and long service life of the unit.



WARNING

unit is not allowed for use by children and persons with reduced physical, mental or sensory capacities, without proper practical experience or expertise, unless they are controlled or instructed on the product operation by the person(s) responsible for their safety.

Children must be under adult supervision in order to avoid playing with the product.



WARNING

Do not dispose in domestic waste.

The unit contains in part materials that can be recycled and in part substances that should not end up as domestic waste.

Dispose of the unit once it has reached the end of its working life according to the regulations valid in your country.

UNIT DESIGN AND OPERATING LOGIC

The ventilator consists of an indoor assembly unit with a decorative front panel, a cartridge, an air duct, a sound absorbing material and an outer ventilation hood.

The cartridge is the basic functioning part of the ventilator.

The cartridge consists of the fan, the heat exchanger and two filters that ensure rough air filtration and prevent ingress of dust and foreign objects into the heat exchanger and the fan.

The indoor assembly unit is equipped with automatic shutters that close during the ventilator standstill and prevent uncontrolled air backflow.

The outer ventilation hood is used to prevent direct ingress of water and other objects to the ventilator.

Round duct Ø 160 mm is made of plastic and is 500 mm long.

The unit is equipped with a high-tech ceramic heat exchanger with heat

recovery efficiency up to 97 %.

Due to the cellular structure it has a larger contact surface and higher efficiency.

The unit is featured with excellent heat-conducting properties and thermal energy storage capacity.

The ceramic heat exchanger uses the heat energy contained in the exhaust air to heat supply air.

Air is supplied and extracted with an axial reversible EC-fan with low energy demand.

The motor has overheating protection and ball bearings for longer service life.

The front panel incorporates an operating LED indicator.

During the night the indicator light intensity drops down.

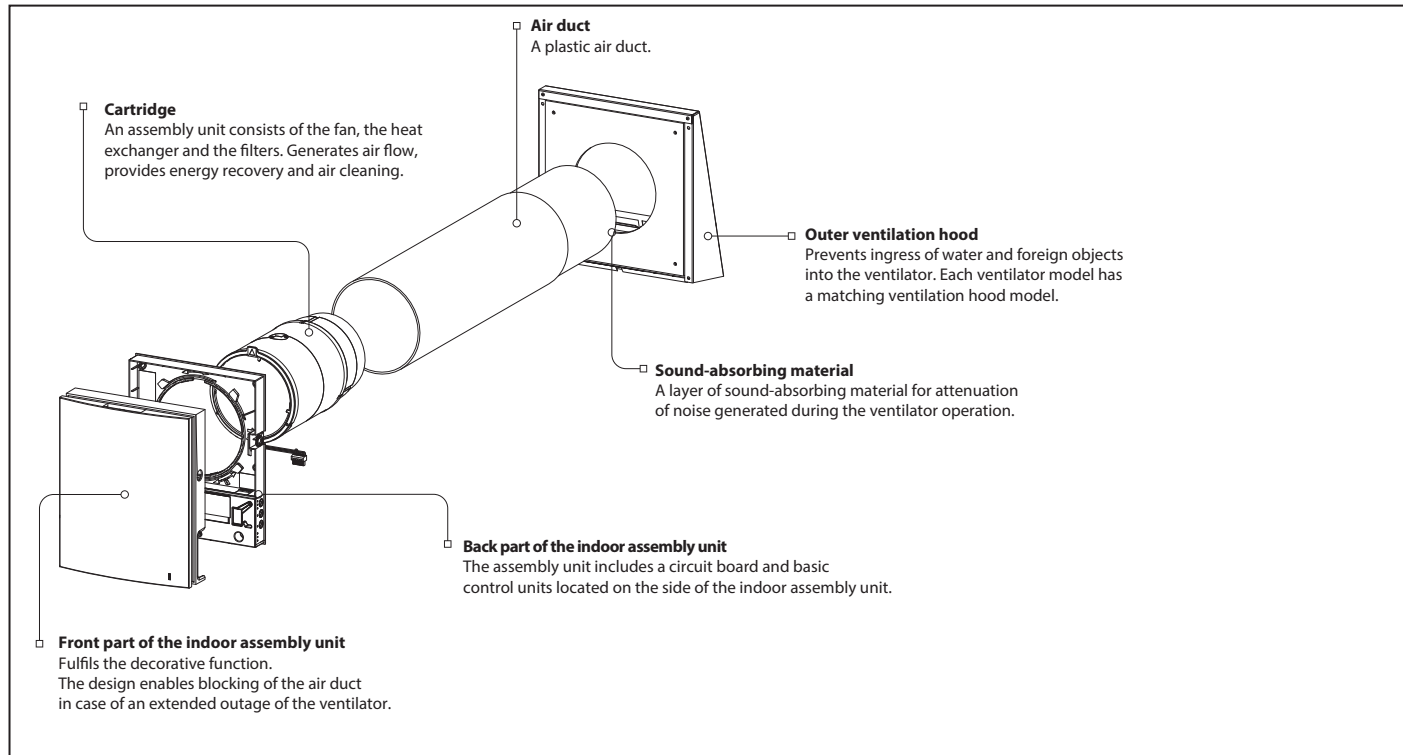
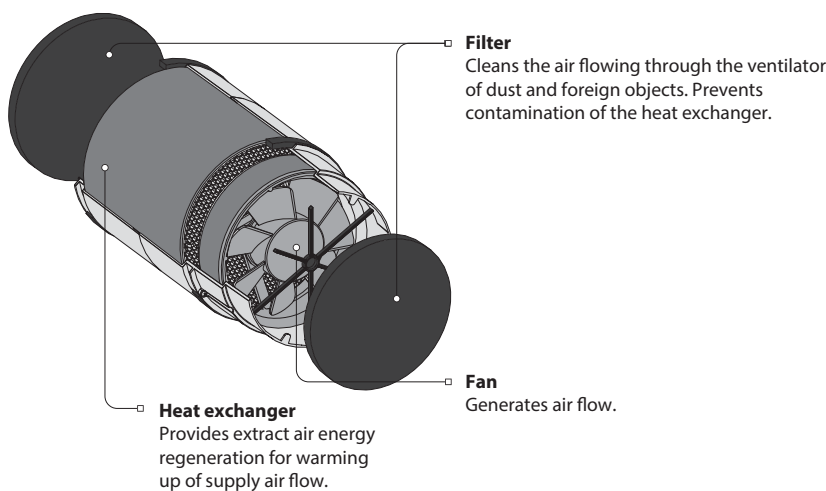

Fig. 1. Unit design

CARTRIDGE DESIGN



Cartridge is a solid block consisting of the fan, the heat exchanger and the filters.

The filters are easy removable for technical maintenance.

AUTOMATIC SHUTTERS OPERATION

The indoor assembly unit is equipped with automatic shutters. During the ventilator operation the automatic shutters are opened and let the air flow freely through the ventilator. The design enables blocking of the air duct in case of an extended outage of the ventilator.

The shutters are closed

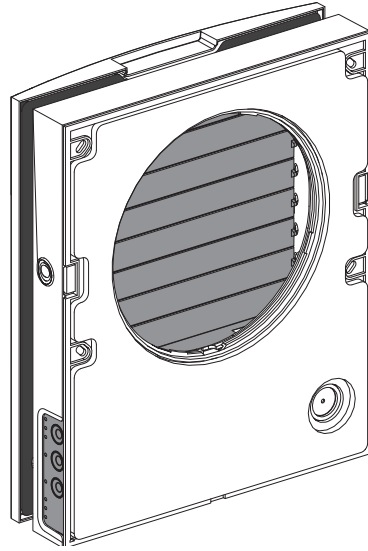

The shutters are opened

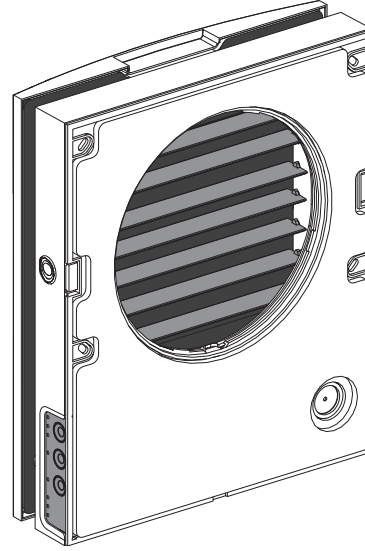

VENTILATOR OPERATION MODES

The ventilator has two operation modes:

Ventilation. The ventilator operates either in extract or supply mode at a set speed.

Regeneration. The ventilator operates in reversible mode with heat and humidity recovery.

In Regeneration mode the ventilator operates in two cycles, 70 seconds each.

Cycle I.

As warm stale extract air flows through the heat exchanger, it heats up and moisturizes the heat exchanger and transfers up to 97 % of heat energy.

Cycle II.

Fresh intake air from outside flows through the ceramic heat exchanger, absorbs accumulated moisture and is heated up to the room temperature. In 70 seconds as the ceramic heat exchanger gets cooled down, the ventilator is switched to air extract mode and the cycle is renewed.

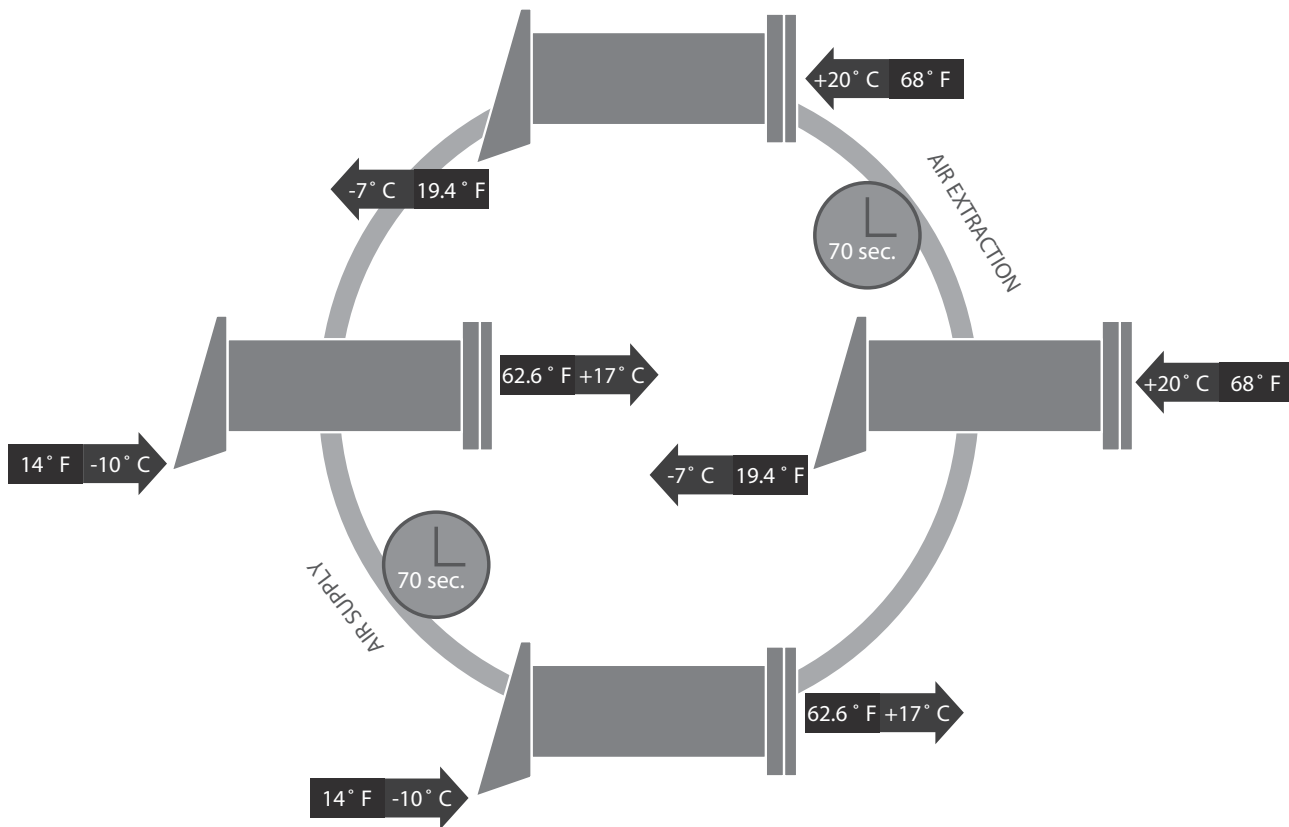

MODIFICATIONS AND OPTIONS

VENTO Expert A50-1 Pro

Unit for 250 up to 490 mm walls.

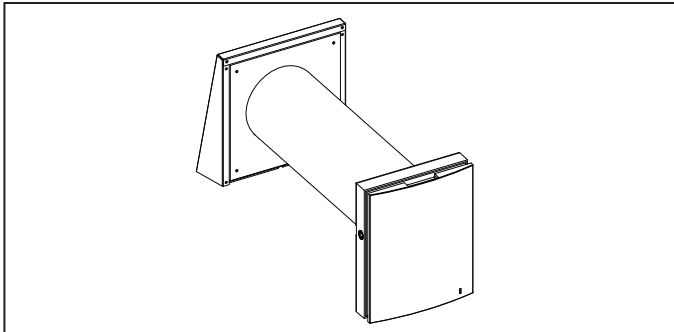

Fig. 2. VENTO Expert A50-1 Pro

VENTO Expert A50-1 S Pro

Unit for 120 up to 490 mm walls.

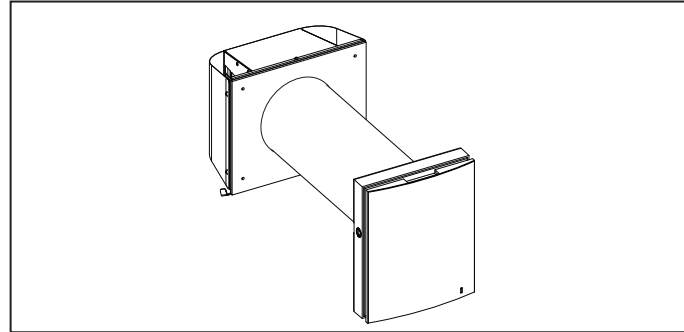

Fig. 3 VENTO Expert A50-1 S Pro

DELIVERY SET

- ✓ Indoor assembly unit of the ventilator - 1 item
- ✓ Air duct - 1 item
- ✓ Sound-absorbing material - 1 item
- ✓ Cartridge assembly - 1 item
- ✓ Outer ventilation hood - 1 item

- ✓ Remote control - 1 item
- ✓ Cardboard mounting plate - 1 item
- ✓ Mounting kit - 1 item
- ✓ Operation manual - 1 item
- ✓ Packing box - 1 item



ATTENTION!

Make sure the unit has no visible transport damages while accepting the goods. Check the ordered and the delivered goods for compliance.

TECHNICAL DATA

Table 1. Unit technical data

Parameters	VENTO Expert A50-1 Pro / VENTO Expert A50-1 S Pro		
Unit voltage [V /50-60 Hz]	1~100-240		
Speed	1	2	3
Total unit power [W]	3.61	4.15	5.2
Total unit current [A]	0.025	0.030	0.039
Max. air capacity [m³/h]	15	30	50
Sound pressure level at 1 m distance [dB(A)]	20	27	30
Sound pressure level at 3 m distance [dB(A)]	11	18	21
Outdoor noise attenuation [dB(A)]	42		
Max. transported air temperature [°C]	from -30 up to +50		
Heat recovery efficiency [%]	97	90	82
Heat exchanger type	ceramic heat exchanger		
Index of protection	IP24		

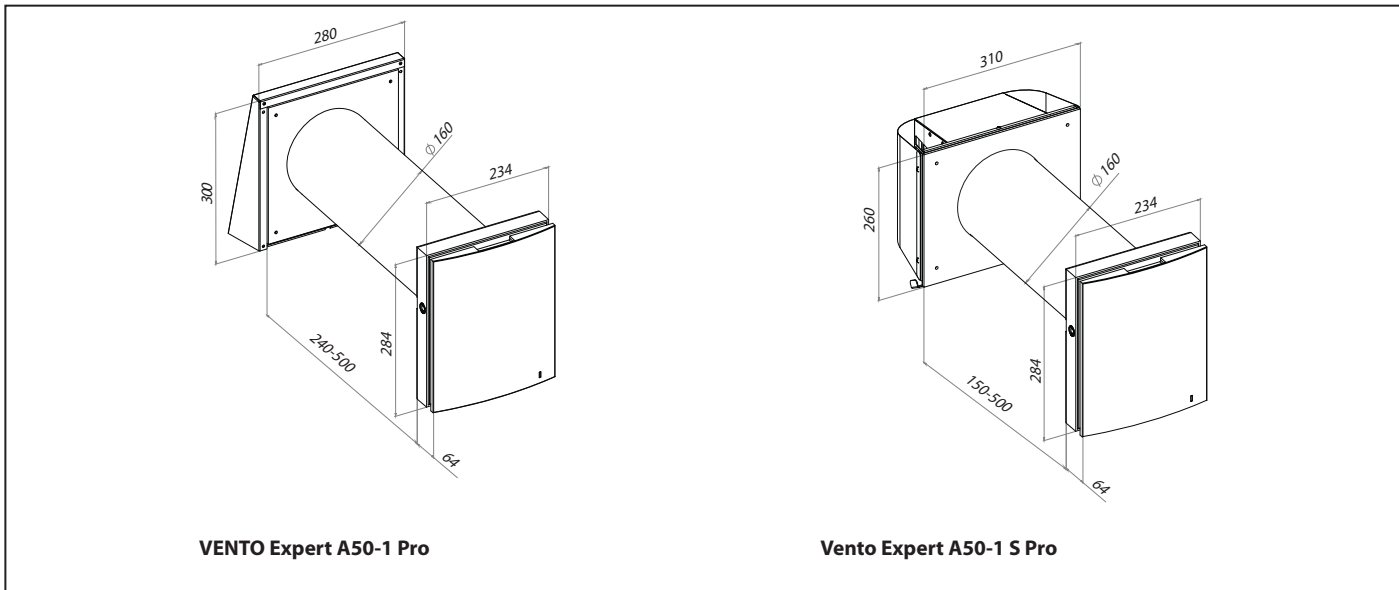

Fig. 4. Overall dimensions

MOUNTING



WARNING

Read the operation manual prior to any electric installations. Connection of the unit to power grid is allowed only by qualified professionals.

The unit is designed for through-the-wall mounting in the building outer wall.

in the figure 5. While preparing a core hole it is recommended to make preparations for layout of the power cable and other required cables.

Mounting sequence:

1. Prepare a round core hole in the outer wall. The core hole size is shown

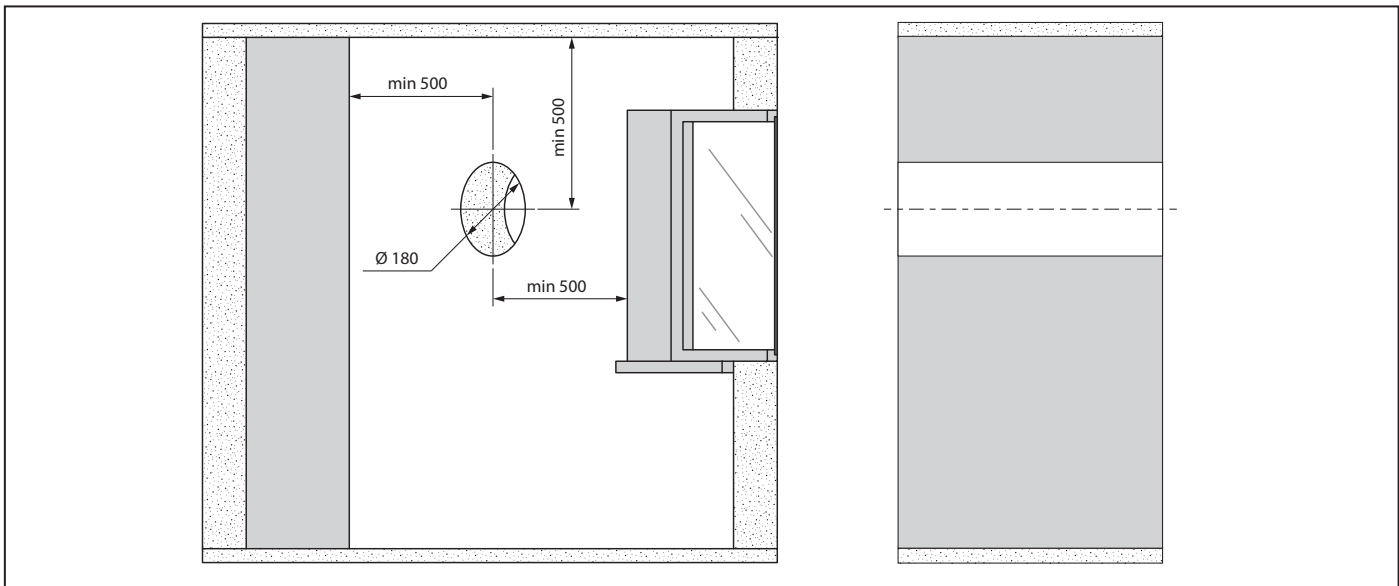

Fig. 5.

2. Insert the air duct in the wall.
 The telescopic air duct end must protrude for the distance A that enables installation of the outer ventilation hood (see Fig. 6).
 Install the air duct in the wall in such a way so it protrudes from the wall

surface for maximum 3 mm or is flush with the wall.
 Install the air duct with the minimum 3° slope downwards.

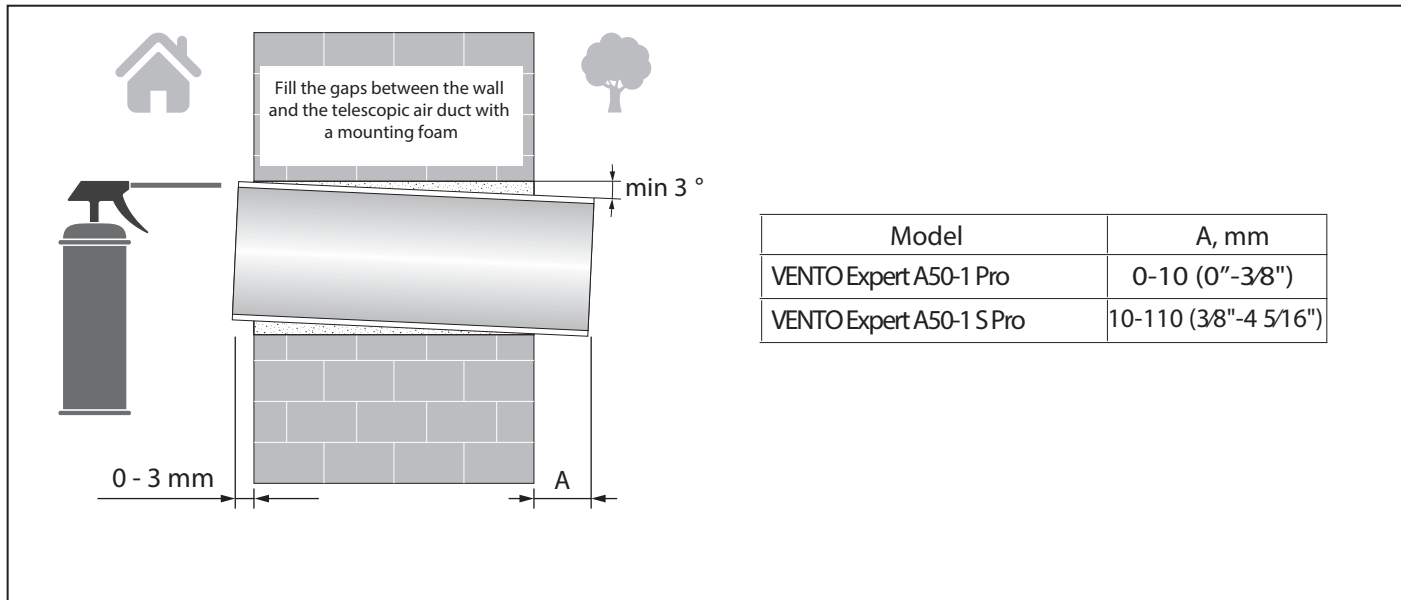

Fig. 6.

3. Stick the delivered cardboard master plate on the indoor wall using a mounting tape. The large opening in the master plate must be axially aligned with the air duct. For aligning of the master plate with respect to the horizon line it is recommended to use a builder's level. Then mark the fastening holes

for installation of the supplied dowels and drill the holes to a required depth.
 Route the power cable from the ventilator outside through the specially marked opening on the master plate.

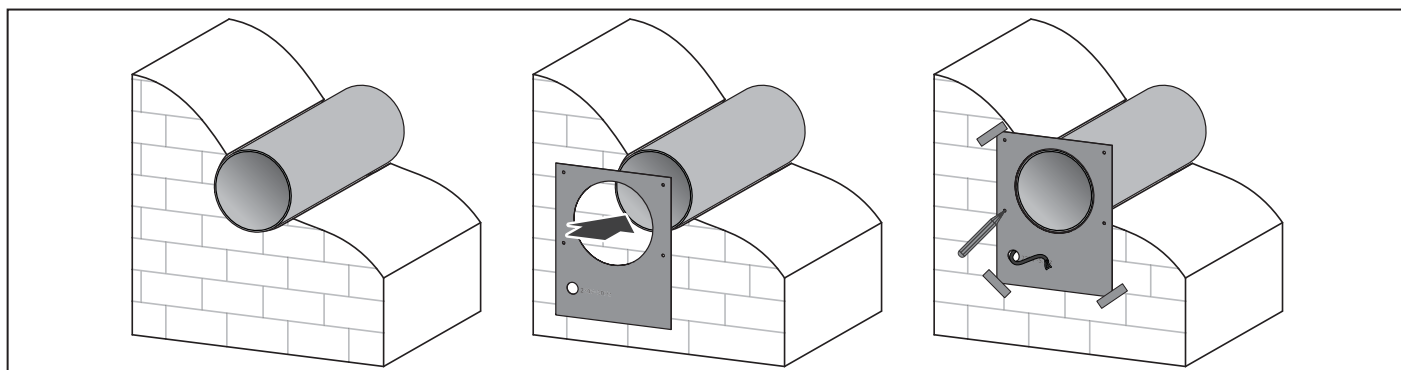

Fig. 7.

4. Unlatch the front part of the indoor assembly unit from its back part by pressing the side tabs. While installing the front panel the thermal actuator rod must be in low position.

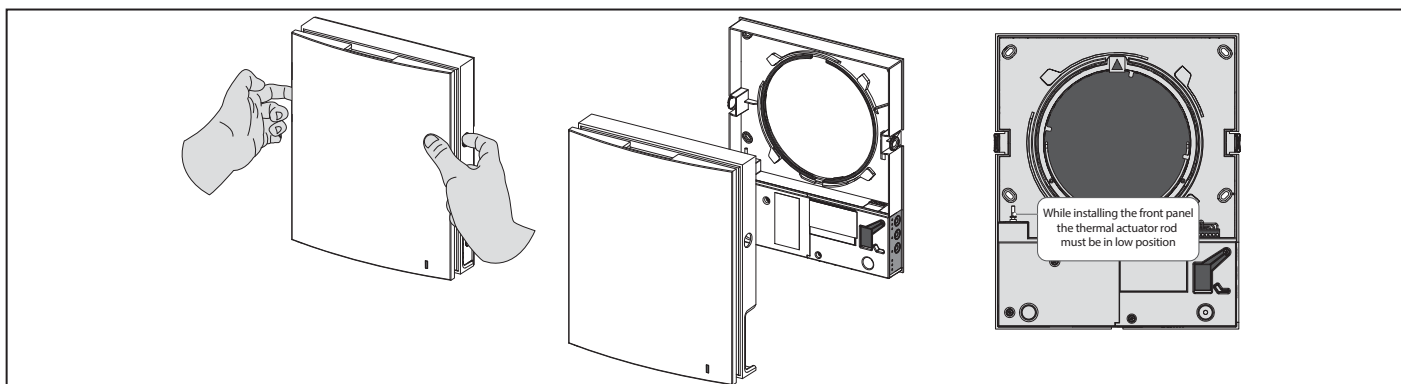

Fig. 8.

5. Fix the back part of the indoor assembly unit on the wall with the screws supplied with the mounting kit of the ventilator. Remove the two retaining

screws from the left transparent cover to enable access to the terminals.

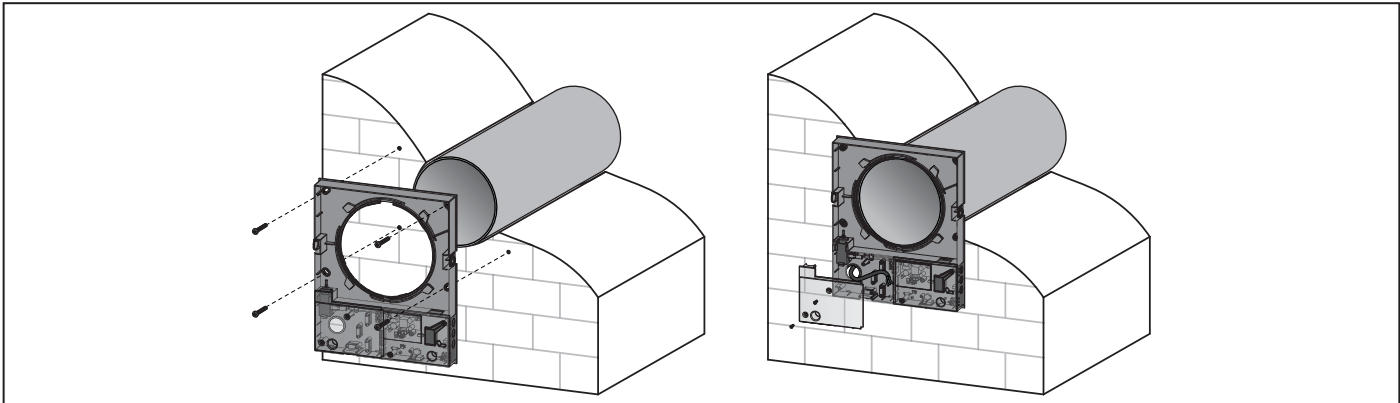

Fig. 9.

6. Route the power cable (see Fig. 10) and connect the ventilator to power mains in compliance with the external wiring diagram (see Fig. 16). Fix the

power cable and the signal cables with a cable clamp. After completion of the electrical connection re-install the transparent cover in site.

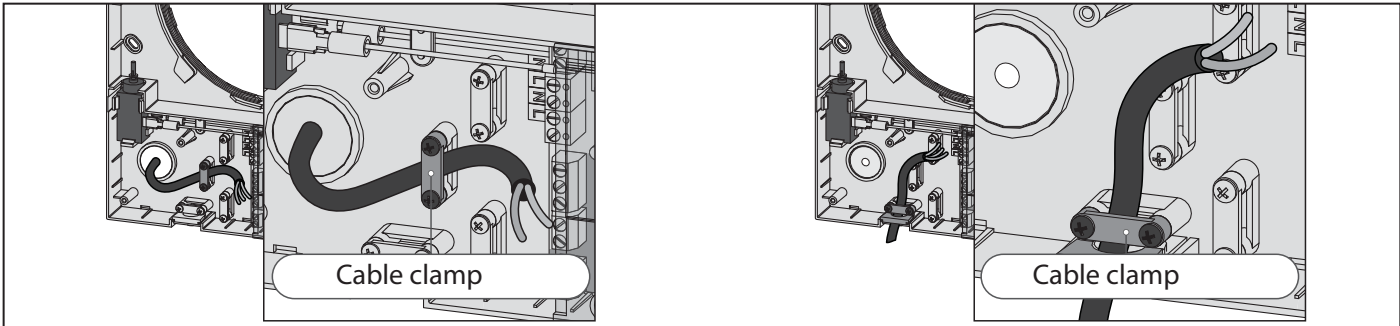

Fig. 10.

7.7. Insert the cartridge into the air duct (see Fig. 11). The pointer must be directed upwards. Then fix the wire with the protruding clamp and connect

the socket connector to the circuit board.

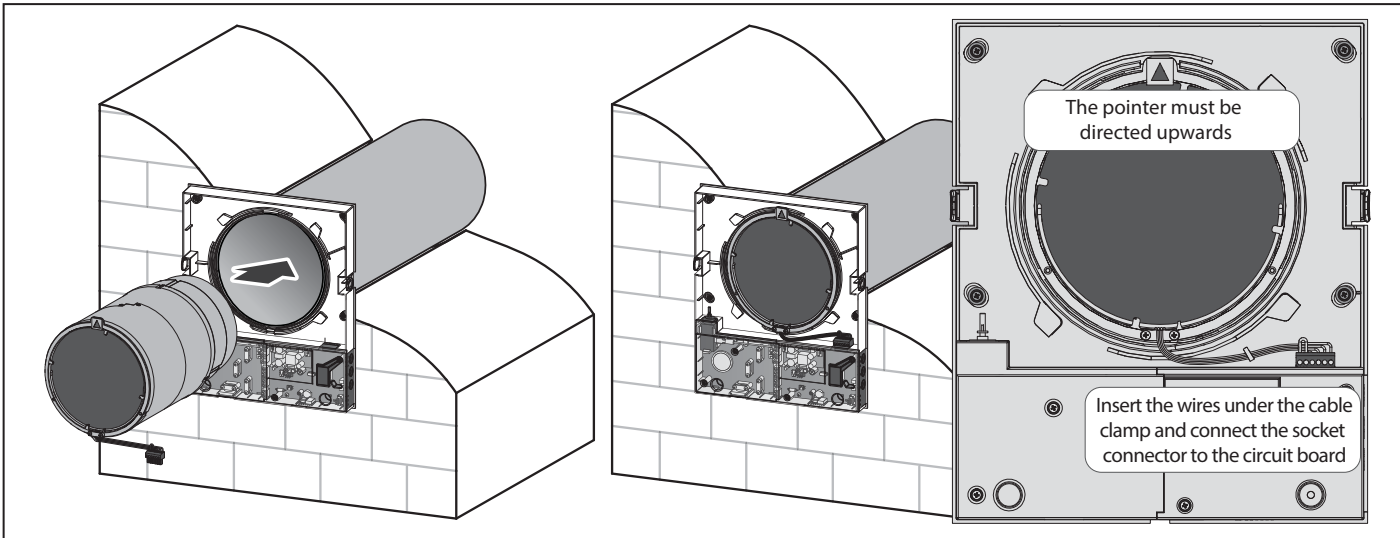

Fig. 11.

8. Mark the fastening holes for the outer ventilation hood:

- Fig. 12a - for VENTO Expert A50-1 Pro model.
- Fig. 12b - for VENTO Expert A50-1 S Pro model.

Drill 40 mm holes for the dowel 6x40. Insert the 6x40 dowels from the delivery set into the holes.

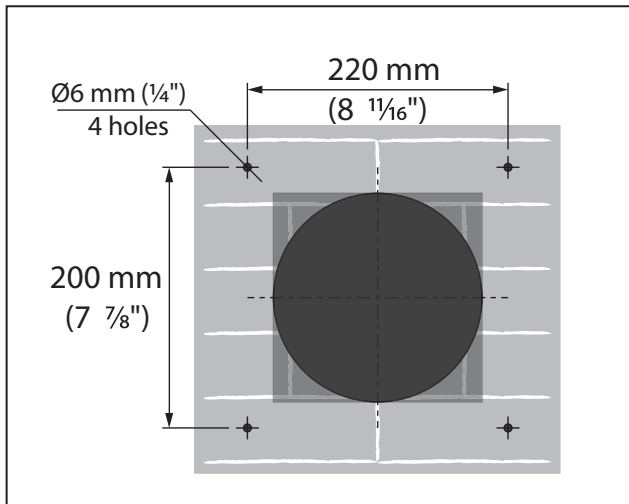

Fig. 12a.

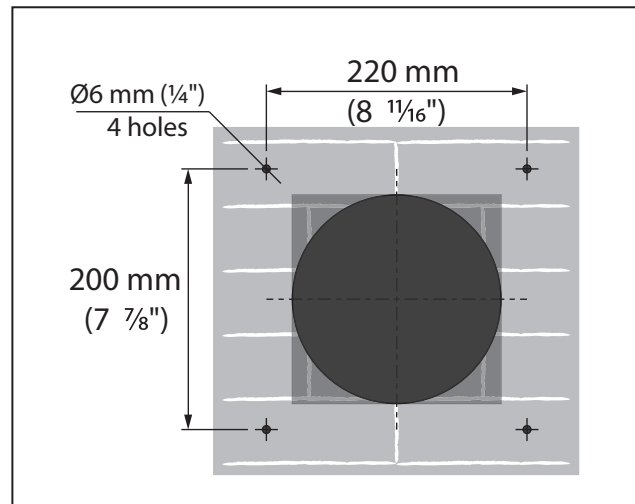

Fig. 12b.

9. Disassemble the outer ventilation hood to enable access to the fastening holes.

- Fig. 13a - for VENTO Expert A50-1 Pro model. Take off the front part of the outer ventilation hood.
- Fig. 13b - for VENTO Expert A50-1 S Pro model. Remove 5 screws and take off the front part of the ventilation hood.

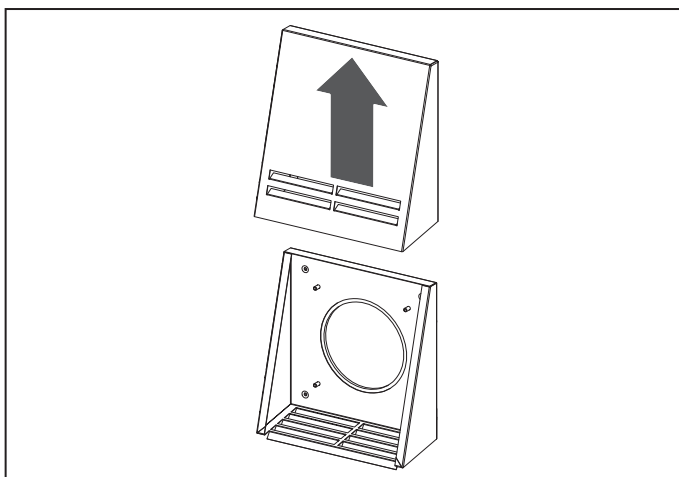

Fig. 13a.

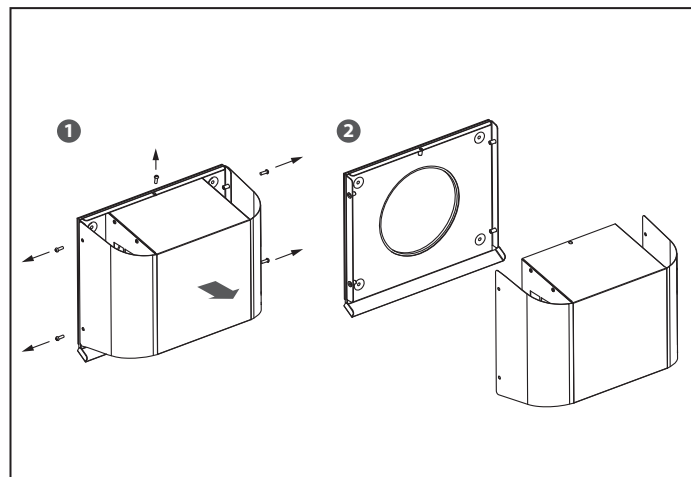

Fig. 13b.

10. Fix the back part of the outer hood on the wall:

- Fig. 14a - for VENTO Expert A50-1 Pro model. Connect the back part of the ventilation hood with the wall using the 4x40 screws from the delivery set.
- Fig. 14b - for VENTO Expert A50-1 S Pro model. Connect the back part of the ventilation hood with the wall using the 4x40 screws from the delivery set.

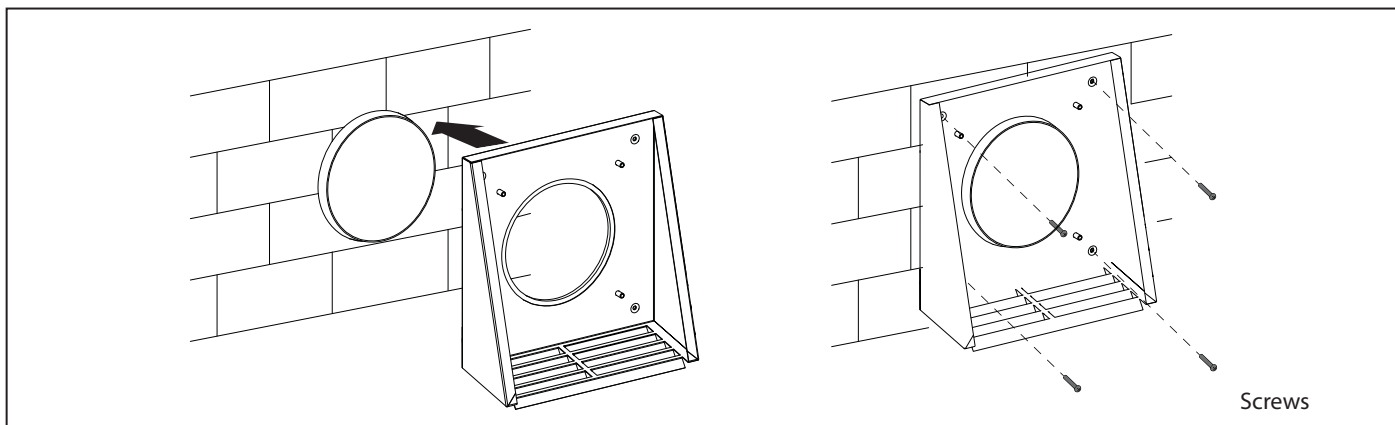
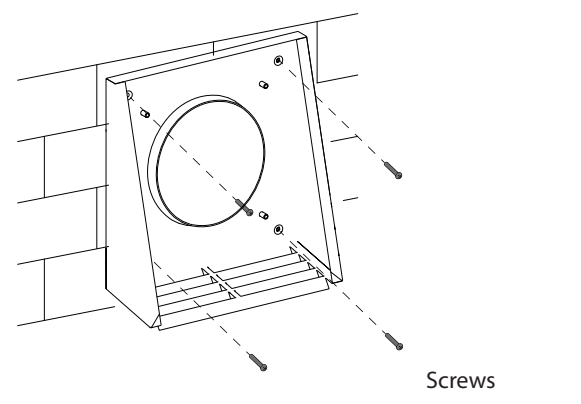

Fig. 14a.



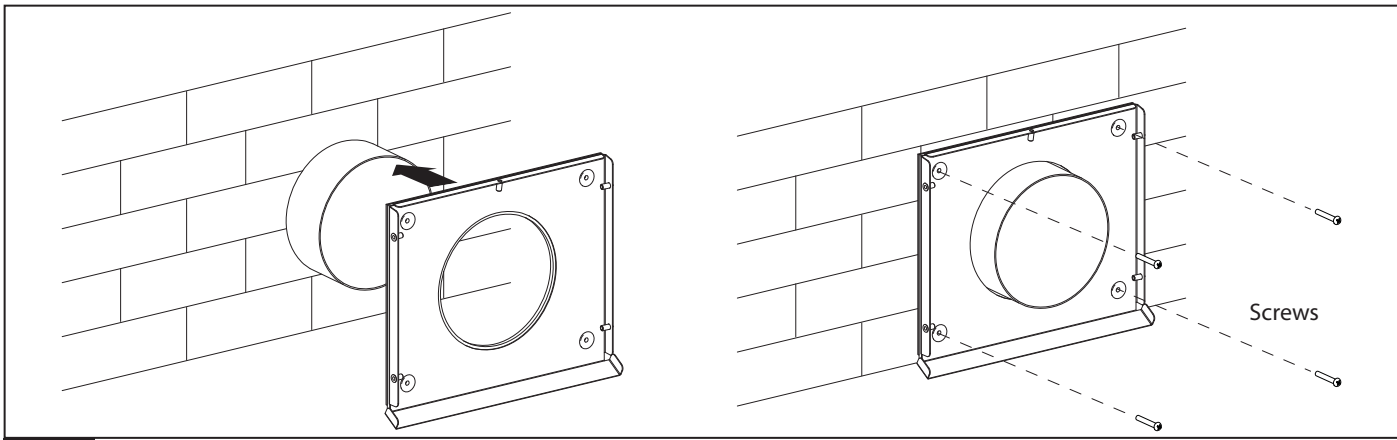

Fig. 14b.

11. Install the front part of the ventilation hood.
- Fig. 15a - for VENTO Expert A50-1 Pro model.
 - Fig. 15b - for VENTO Expert A50-1 S Pro model.

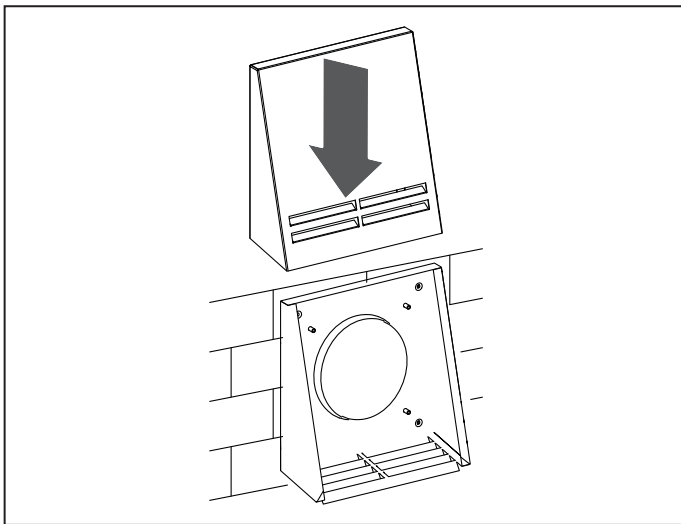

Fig. 15a.

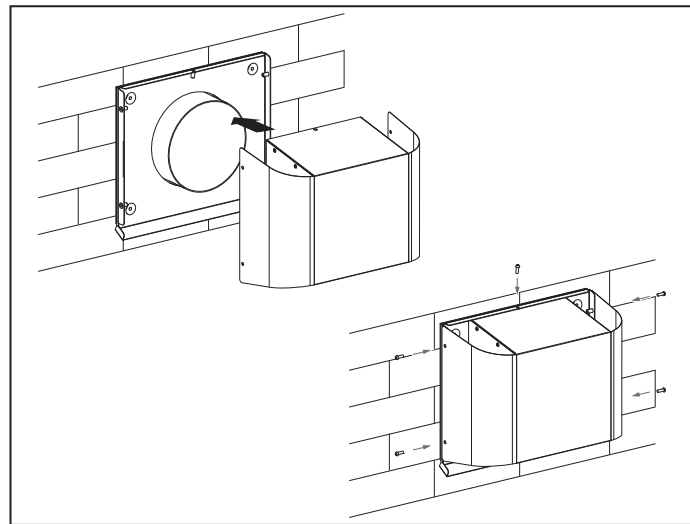

Fig. 15b.

CONNECTION TO POWER MAINS



WARNING

Connection of the unit to power grid is allowed by a qualified electrician only after reading the operation manual prior to any electric installations.

The rated electrical parameters are stated on the rating plate.

Any tampering with the internal connections is prohibited and will void the warranty.

Connect the unit only to power mains with valid electric standards.

The unit must be connected to a correct mounted socket with a grounded terminal or connected to a fixed installed cable.

Follow the respective electric standards, safety rules (DIN VDE 0100), TAB der EVUs.

The house cabling system must be equipped with a magnetic trip automatic switch at the external input. The contact gap on all poles must be at least 3 mm (VDE 0700 T1 7.12.2 / EN 60335-1).

Enable quick access to an automatic switch installation place.

The unit is rated for connection to a single-phase AC with a voltage of 100-240 V / 50-60 Hz.

The routing of the power and signal cables is shown in "Mounting" section.

For electric installations use insulated, durable and heat-resistant electric leads (cables, conductors) with the minimum cross section 0.75 mm² for the power cable and 0.25 mm² for the signal cables.

The cable cross-section is given for reference only.

The signal cable must be shielded.

The actual conductor cross-section selection must be based on its type, the maximum permissible heating, insulation, length and installation method.

Use copper wires for all the electric connections!

Connect the unit to power grid via the terminal block installed in the control circuit in compliance with wiring diagram and terminal designation.

Connect the unit to power mains through the external automatic switch with a magnetic trip integrated into the fixed wiring system.

The trip current of the automatic switch must exceed the ventilator current consumption, refer to Table 1.

The ventilator design enables connecting any external controls with a normally opened contact (NO-contact), such as an external CO₂ sensor, humidity sensor, relay switch, etc.

When the contacts NO1 and NO2 are closed the ventilator switches to maximum speed.

Several ventilators may be in series or parallel connected to power mains with a central control by the master ventilator.

In case of in-series or parallel connection of several ventilators power is supplied either from a previous ventilator or from power grid.

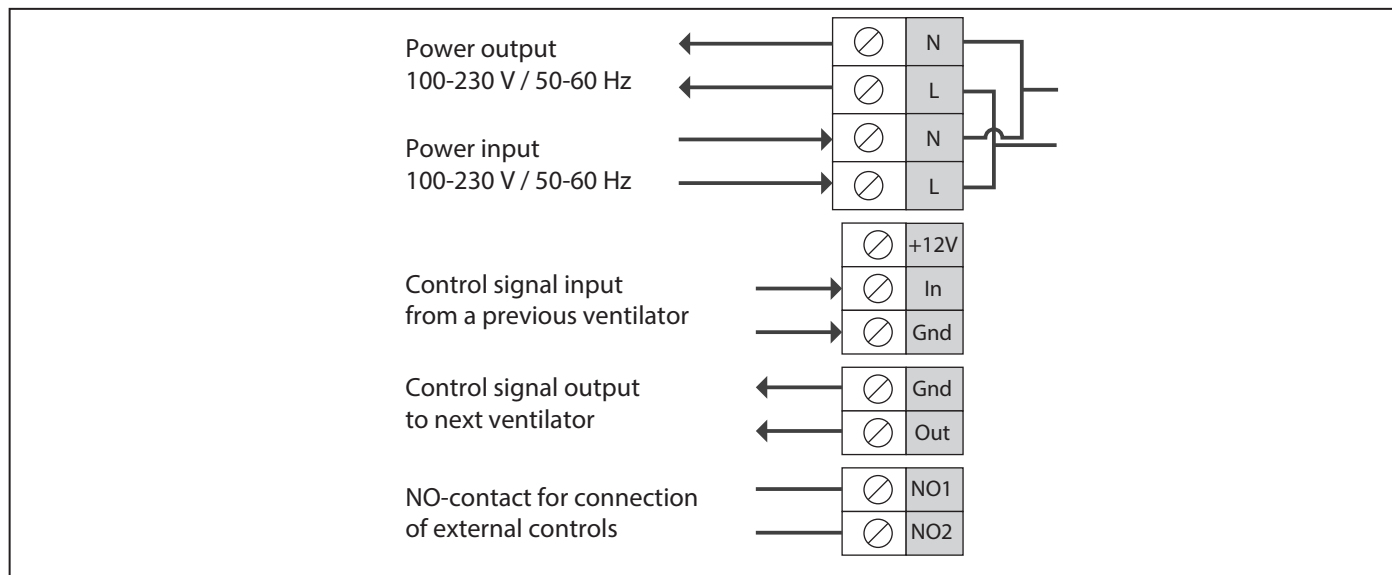
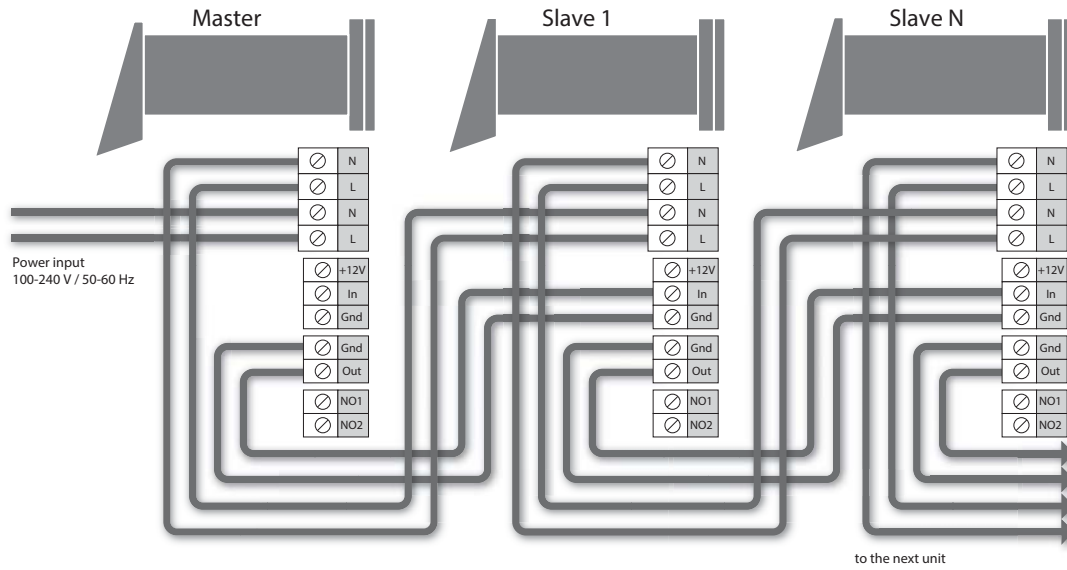
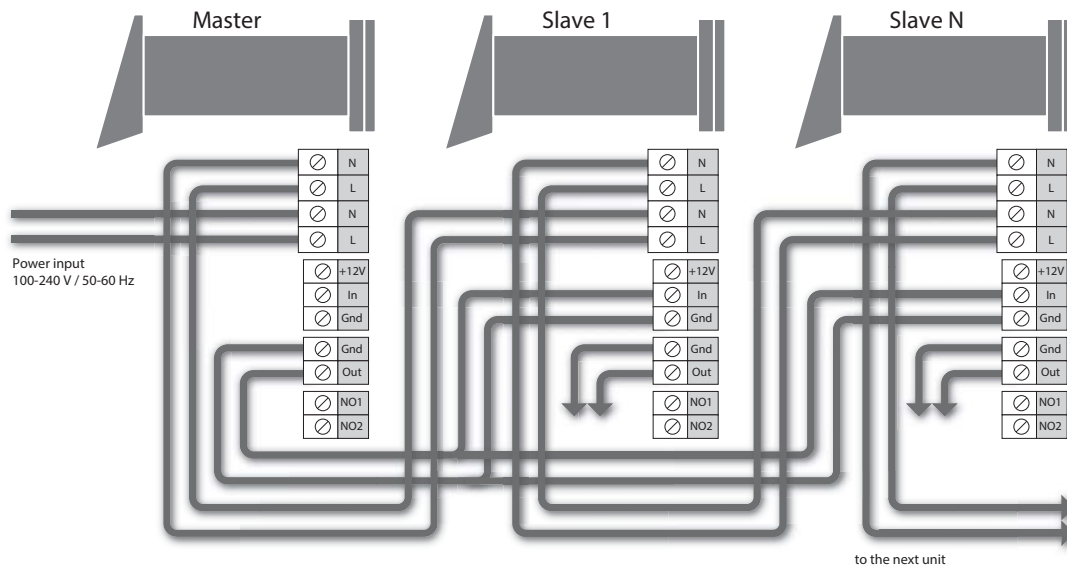

Fig. 16. External wiring diagram

WIRING DIAGRAM FOR IN-SERIES CONNECTION



WIRING DIAGRAM FOR PARALLEL CONNECTION



UNIT SETUP

Prior to operating the ventilator set up the ventilator using the DIP-switch. It is located on the controller circuit board.

To access the DIP-switch take off the front panel of the indoor assembly unit and uplift the rubber plug that covers the switch.

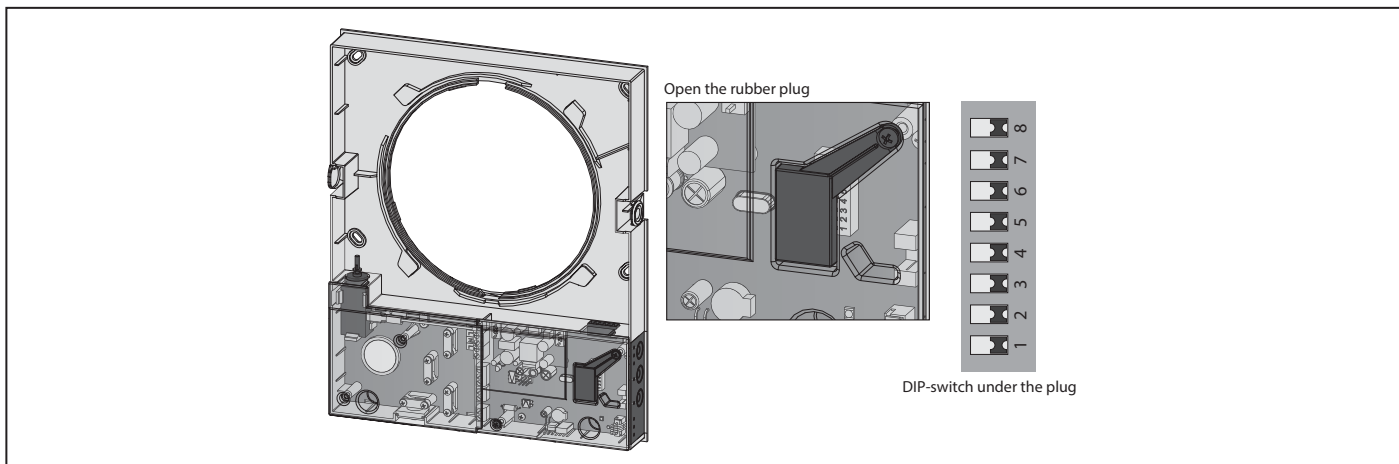































Fig. 17. DIP-switch

Table 2. DIP-switch Positioning

Position	Function
 1	Turning the unit off is allowed. The switch position enables deactivation of the unit with the button on the side control panel.
 1	Turning the unit off is forbidden. The switch position disables deactivation of the unit with the button on the side control panel.
Fan rotation direction. For controlled ventilation it is recommended to install the units pairwise and integrate them in a group using a signal cable. Set one half of the connected units into supply mode and the other half into extract mode.	
 2	Air supply. This positioning of the switch enables supply operation of the unit in Ventilation mode. In Regeneration mode the unit starts operating first in supply mode.
 2	Air extract. This positioning of the switch enables extract operation of the ventilator in Ventilation mode. In Regeneration mode the ventilator starts operating first in extract mode.
Humidity sensor setpoint. The humidity sensor measures the extract air humidity. If the extract air humidity is above the set point, the ventilator switches to Speed III. As humidity drops down to the set point, the ventilator changes to pre-set speed after elapsing of the time set on the delay timer.	
 5  4  3	Humidity control is OFF
 5  4  3	Humidity setpoint 40 %
 5  4  3	Humidity setpoint 50 %
 5  4  3	Humidity setpoint 60 %
 5  4  3	Humidity setpoint 70 %
 5  4  3	Humidity setpoint 80 %
Delay timer. During activation of the humidity sensor or any other control unit the unit switches to higher speed. After standardization of the indoor humidity or any other air parameters the unit returns to a previously set mode after set time period.	
 7  6	Time delay 0 min
 7  6	Time delay 5 min
 7  6	Time delay 15 min
 7  6	Time delay 30 min

UNIT CONTROL

The ventilator can be operated with the remote control or the control buttons on the side part of the indoor assembly unit, as figured below.

In case of in-series or parallel connection the signal from a control unit is received by the first ventilator (Master) only.

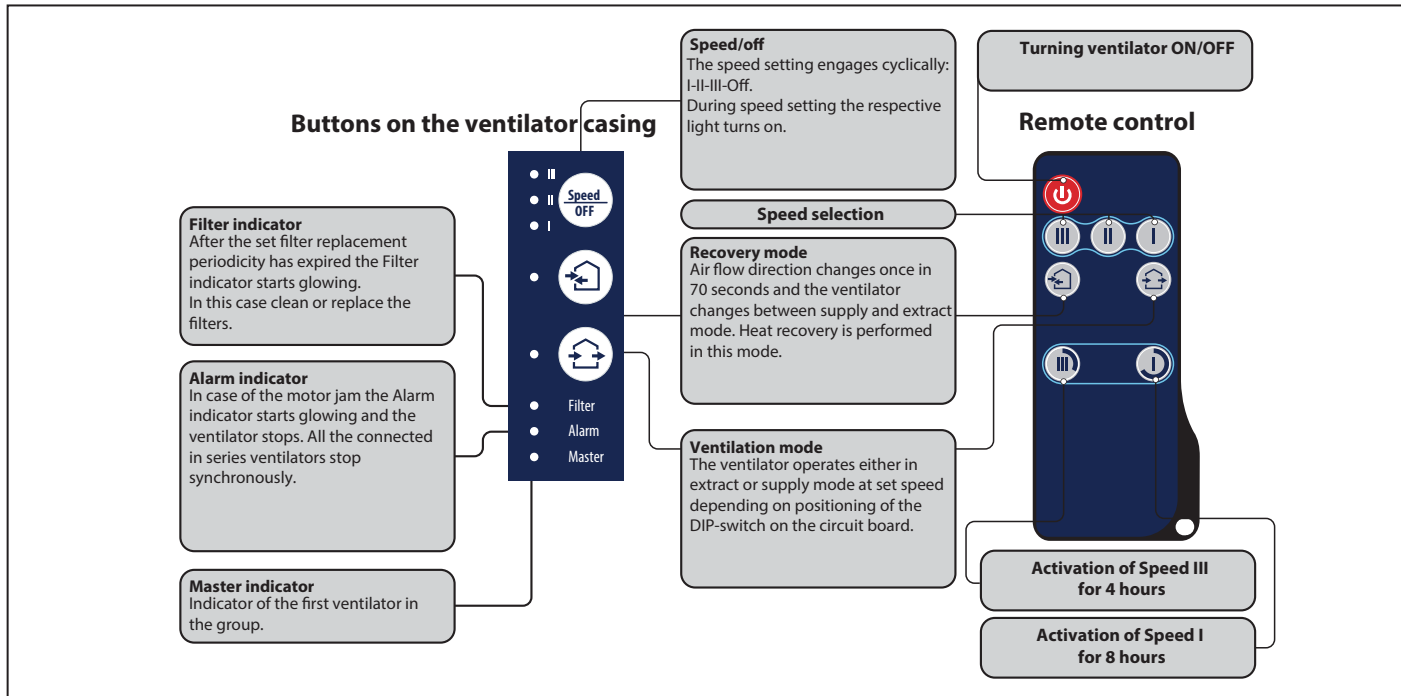

Fig. 18. Unit control

Air flow blocking.

Press the front panel gently to cut off the air duct. The unit will turn off. To open the air duct pull the front panel while holding the special grooves.

The unit reverts to the pre-set operation mode that was active before the air duct shut-off.

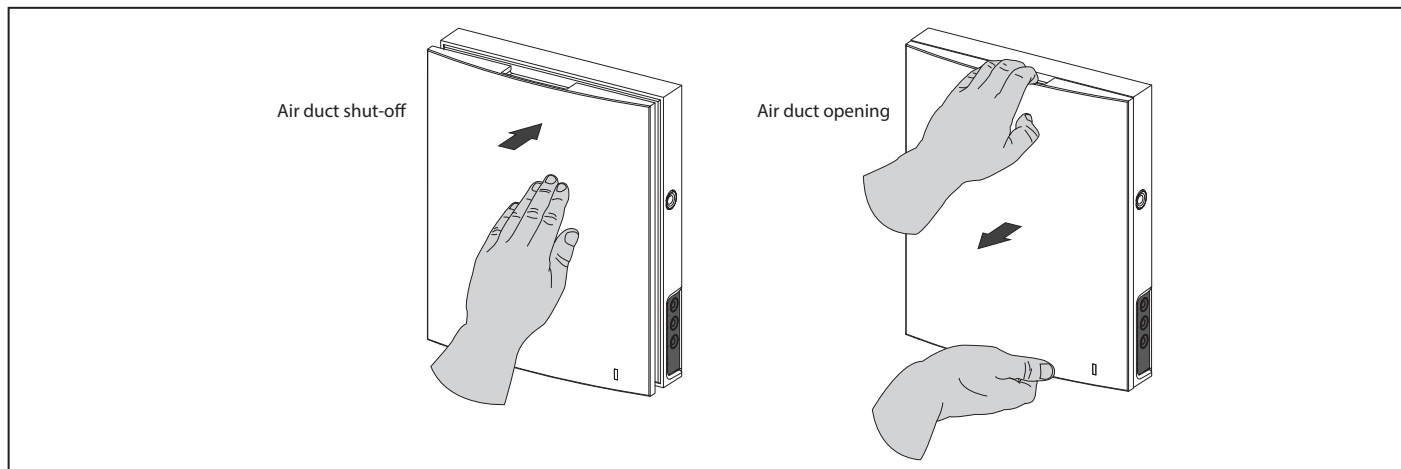

Fig. 19. Air flow shut-off

TECHNICAL MAINTENANCE



WARNING

Disconnect the unit from power supply before any maintenance operations.

Maintenance of the unit means regular cleaning of the ventilator surfaces of dust and cleaning or replacement of the filters.

To access the basic assembly units follow the steps:

1. Press the latches on the side of the indoor assembly unit to take off the front part. When re-installing the front panel the thermal actuator rod must be down. If it is uplifted, wait until it goes down about 2 minutes.

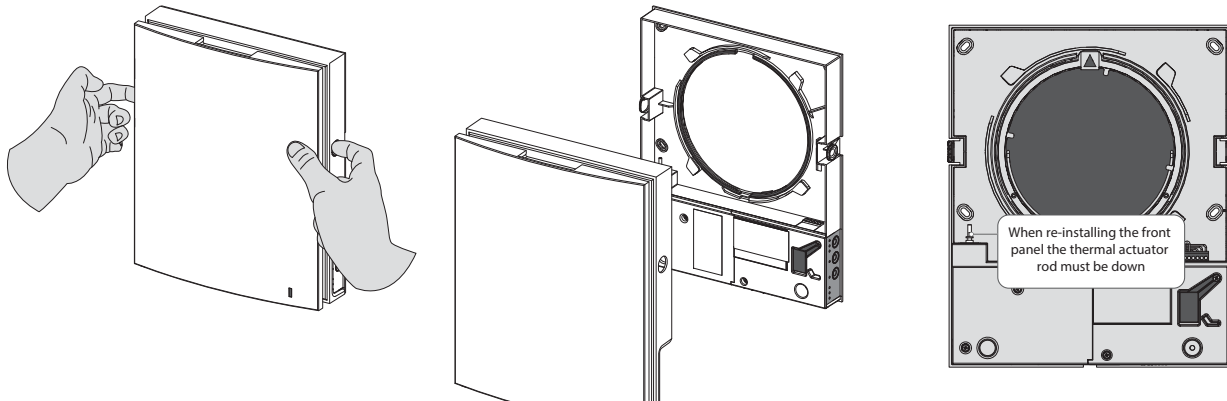

2. Disconnect the socket from the circuit board. While removing the socket do not pull the cable. Uplift it with a flat screw driver of a respective size.

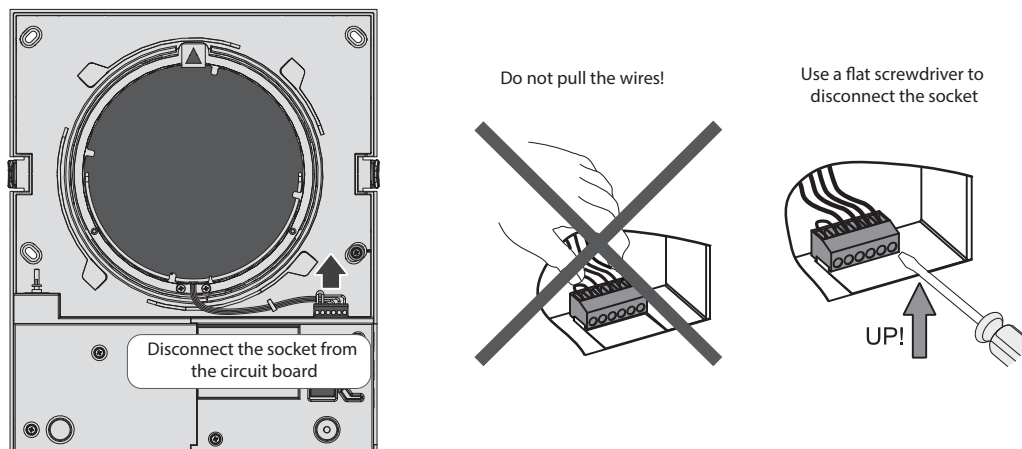

3. Pull the cord to remove the cartridge from the air duct. Remove the filters from the cartridge.

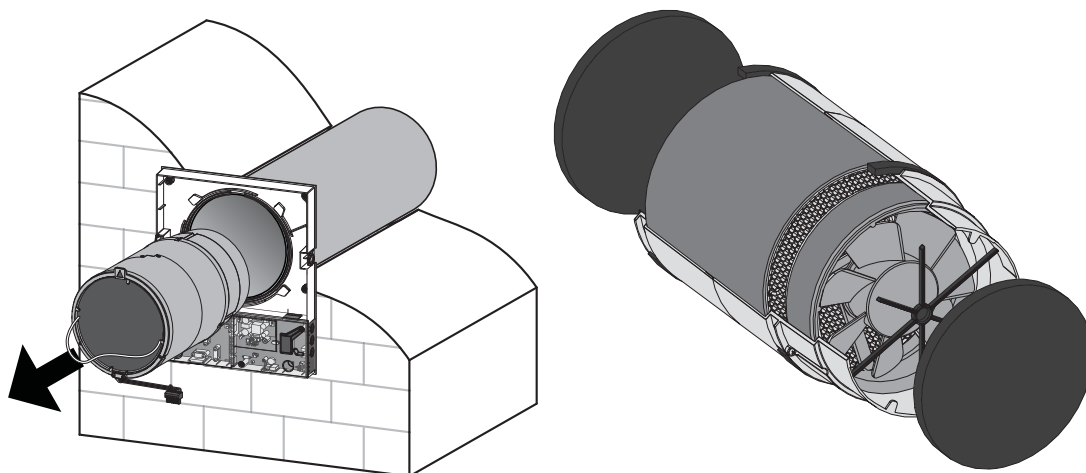

Cleaning of the filters.

Clean the filters as they get soiled, but not less than once in three months. After the set filter replacement periodicity has expired the Filter indicator starts glowing. The filter timer is reset once the cartridge socket is disconnected from the circuit board. Wash the filters and let them get dry. Install dry filters in the air duct. Vacuum cleaning is allowed. The filter rated service life is 3 years.

For new filters contact your distributor.

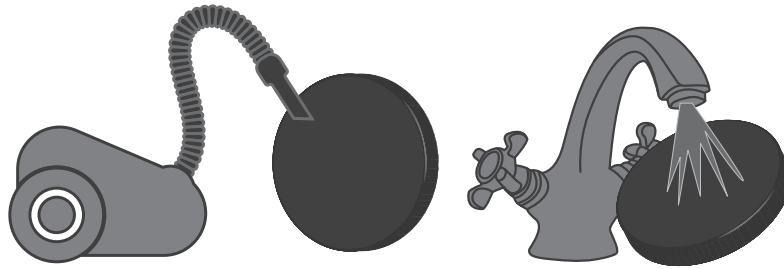
**Cleaning of the heat exchanger.**

Some dust may accumulate on the heat exchanger block even in case of regular maintenance of the filters. Clean the heat exchanger regularly to ensure its high heat recovery efficiency. Vacuum clean the heat exchanger not less than once a year.

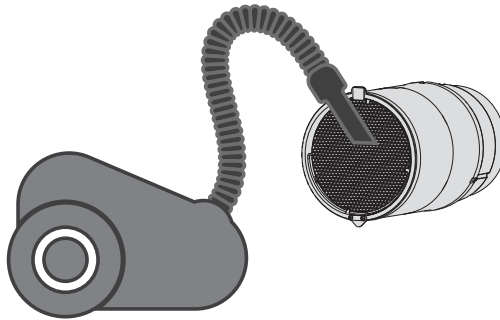
**Replacement of the remote control battery (if necessary).**

In case of a long operation of the remote control the battery must be replaced. If the ventilator does not respond to the commands from the remote control it is a signal to replace the battery. Battery type: CR2025. To replace the battery of the remote control remove the battery holder with a battery.

Replace the battery and install the holder with a new battery back to the remote control.

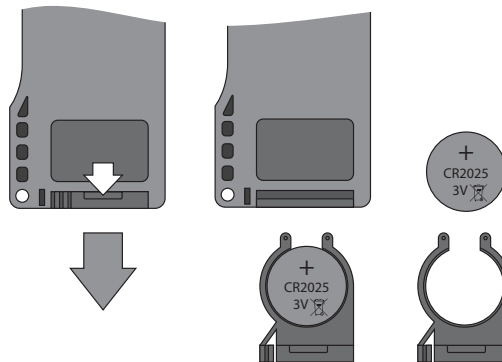
**Outer ventilation hood maintenance (once per year).**

The ventilation hood may get clogged with leaves and other objects which may reduce the unit performance. Check the ventilation hood twice per year and clean it as often as required.

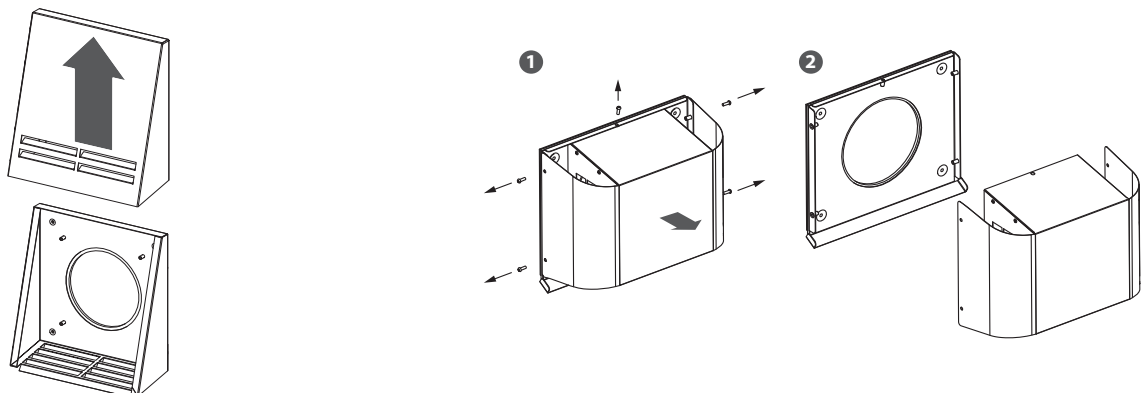

TROUBLESHOOTING

Fault	Possible reasons	Troubleshooting
When switching on the unit the fan does not start.	No power supply.	<ul style="list-style-type: none"> • Make sure the power supply line is connected correctly, otherwise troubleshoot the connection error.
	The motor is jammed, the impeller blades are soiled.	<ul style="list-style-type: none"> • Turn the unit off. • Troubleshoot the motor jam and the impeller clogging. • Clean the blades. • Restart the unit.
Automatic switch tripping following the unit turning on.	Overcurrent as a result of short circuit in the electric line.	<ul style="list-style-type: none"> • Turn the unit off. • Contact the distributor.
Low air flow.	Low set fan speed.	<ul style="list-style-type: none"> • Set higher speed.
	The filter, the fan or the heat exchanger is soiled.	<ul style="list-style-type: none"> • Clean or replace the filter. • Clean the fan and the heat exchanger. • For the heat exchanger and the filter maintenance, refer to page 17.
Noise, vibration.	The impeller is soiled.	<ul style="list-style-type: none"> • Clean the impeller.
	Loose screw connection of the unit casing or the outer ventilation hood.	<ul style="list-style-type: none"> • Tighten the screws of the unit or the outer ventilation hood.

ACCEPTANCE CERTIFICATE

Heat recovery single room unit with heat and humidity recovery

VENTO Expert A50-1 Pro		VENTO Expert A50-1 S Pro	
------------------------	--	--------------------------	--

is recognized as serviceable.

The unit complies with the requirements according to the EU norms and directives, to the relevant EU-Low Voltage Equipment Directives, EU-Directives on Electromagnetic Compatibility.

We hereby declare that the unit complies with the essential protection requirements of Electromagnetic Council Directive 2004/108/EC, 89/336/EEC and Low Voltage Directive 2006/95/EC, 73/23/EEC and CE-marking Directive 93/68/EEC on the approximation of the laws of the Member States relating to electromagnetic compatibility, which relate to electrical appliances used in set voltage classes.

This certificate is issued following test carried out on samples of the product referred to above.

Quality Inspector's Stamp

Manufacture Date _____

CONNECTION CERTIFICATE

Heat recovery single room unit with heat and humidity recovery

VENTO Expert A50-1 Pro		VENTO Expert A50-1 S Pro	
------------------------	--	--------------------------	--

is connected to power mains in compliance with the operation manual requirements by the professional:

Company: _____

Expert's Full Name _____

Date _____ Signature _____

WARRANTY CARD

VENTO Expert A50-1 Pro		VENTO Expert A50-1 S Pro	
------------------------	--	--------------------------	--

SELLER

PURCHASE DATE

REPRESENTATIVE IN EU

BLAUBERG Ventilatoren GmbH
Aidenbachstr. 52a,
D-81379 Munich, Germany



BLAUBERG
Ventilatoren



www.blaubergventilatoren.de
VENTO Expert A50-1 Pro / v.4 (2 / EN)

